



**City of Weston, WV
Regular Session City Council Meeting
Lewis County Court House
December 6, 2021, at 6:00 p.m.**

Call In# - (415) 762-9988
Meeting ID: 482 656 4989
Pass Code: 269

AGENDA

Full Agenda Packets Available on www.CityofWestonwv.com

- 1) Call to Order/Moment of Silence
- 2) Pledge of Allegiance
- 3) Roll Call
- 4) Approval of Minutes
 - A) Regular Session – November 1, 2021
 - B) Special Session – November 10, 2021
 - C) Special Session – November 15, 2021
 - D) Special Session – November 30, 2021
- 5) Presentations:
 - A) Public Hearing on Federal Assistance for Police Cruisers
- 6) Receive and File Reports of City Boards, Commissions and Outside Agencies
 - A) Reports
 - i) **Weston Cemetery Board**
 - Next Meeting –Monday, February 14, 2022 at 9:00 a.m. at the Municipal Building
 - ii) **Historic Landmarks Commission**
 - Next Meeting – Thursday, December 9, 2021 at 5:00 p.m. at the Municipal Building
 - iii) **Weston Planning Commission**
 - Next Meeting –Wednesday, February 9, 2021 at 4:30 p.m. at the Municipal Building
 - iv) **Boards of Parks and Recreation**
 - Next Meeting – Friday, March 18, 2022 at 2:00 p.m. at the Municipal Building
 - v) **Lewis County EDA Authority**
 - Next Meeting – Wednesday, December 22, 2021 at 5:00 p.m. at 110 Center Avenue, 2nd Floor
 - Minutes available on online packet
 - vi) **Board of Zoning Appeals**
 - Next Meeting – Tuesday, December 14, 2022 at 6:00 p.m. at the Municipal Building
 - vii) **Codes Appeals Board**
 - Next Meeting Thursday, December 16, 2022 at 6:00 p.m. at the Municipal Building
 - viii) **Outside Agencies**
 - ACP Restoration Project & SHP Restoration Project Docket (received in mail)
 - B) Known Vacancies to be Filled
 - i) **Municipal Appeals Board – (2)**
 - Application for Municipal Appeals Board Ray Smith (Approve/Deny/Table)
 - City Council Appointed Member (Approve/Deny/Table)
 - ii) **Historic Landmarks Commission**
 - Application for Historic Landmarks Kristen Bailey (Approve/Deny/Table)
- 7) Sanitary Board Director Report

8) Department Reports

- A) Finance
 - Suttle & Stalnaker CPA Monthly Financial Report for November 2021
- B) Street Department
 - November Report in Packet
- C) Police Department
 - November Report in Packet
- D) Fire Department
 - November Report in Packet
- E) Building/Code/Zoning Report
 - November Report in Packet
- F) City Attorney
 - November Report
- G) City Clerk
 - November Business Licenses Issued Report in Packet
- H) City Manager Report
 - Paving
 - Windows at City Building

9) Old Business

- A) Discussion on Status of Vacant Building Ordinance
- B) Discussion on 4th Street Bridge Construction over Polk Creek
- C) Update and Reconsideration of Demolition Bids (Approve/Deny/Table)
- D) Extension of Street Department Temp Employee Caden Oldaker (Approve/Deny/Table)

10) New Business

- A) Ordinance Allocating \$350,000 to Weston Sanitary Board for Sludge Removal (First Reading) (Approve/Deny/Table)
- B) Haleville/Shadybrook Property Given to WV DOT-DOH for Bridge Ordinance (First Reading) (Approve/Deny/Table)

11) Visitors Section (5 Minute Time Limit)

12) Reports of City Council

13) Adjourn

Meeting Management Guidelines

- Regular meeting agendas will be posted and available to the public before closure two (2) days prior to the meeting.
- Person wishing to address City Council must register at least fifteen (15) minutes before meeting.
- Agenda items may require an executive session motioned per WV Code 6-9A-4.
- All votes are unanimous unless otherwise stated.
- Roberts Rule of Order is utilized as a guide for all Weston City Council meetings.

4. Approval of Minutes



Weston City Council
Minutes

Lewis County Court House
117 Center Avenue
Weston, WV 26452
November 1, 2021
6:00 p.m.

Present: Mayor Kim Harrison-Edwards, Councilpersons Sherry Rogers, Randy Bohan, Debbie Gump, and Herb Curtis. City Manager Nate Stansberry, City Clerk Judy Piercy, City Attorney Brian Bailey, Chief Josh Thomas, Chief Jimmy Suttle, Street Foreman Tyler Strader, Building/Code/Zoning Enforcement Officer Mike Starett and Sanitary Board of Director Dee Evans.

Call to Order: Mayor Harrison-Edwards called the meeting to order at 6:07 p.m.

Pledge of Allegiance: Mayor Harrison-Edwards asked all to stand for the Pledge of Allegiance.

Approval of Minutes: Councilman Bohan made a motion seconded by Councilwoman Gump to **approve** minutes for the Regular Session October 4, 2021, Special Session October 14, 2021, Special Session October 19, 2021. **Motion carried.**

Presentations:

American Water Inclusion and Diversity Grant Program Columbia Club \$2500 No Match Grant (Approve/Deny/Table): Victoria Stansberry gave a brief overview of the grant with West Virginia being the first American Water state to dedicate funding to community organizations for the purpose of advancing inclusion and diversity related initiatives. Victoria Stansberry informed council that this grant would be used for the Columbia Club programming. In the application they suggested several of diversity groups, we chose women and veterans. This money will allow us to host a series of features with women and veterans who are artists, authors, musicians, a skill to be shared. Councilwoman Rogers made a motion seconded by Councilman Bohan to **approve** submission of the application for American Water inclusion and diversity grant program for the Columbia Club for \$2500.00 (**Roll call of votes, Councilwoman Rogers yea, Councilman Bohan yea, Councilwoman Gump yea, Councilman Curtis yea**). **Motion carried.**

Receive and File Reports of City Boards, Commissions, and Outside Agencies

Reports:

- i) **Weston Cemetery Board** – Next Meeting on Monday November 8, 2021 at 9:00 a.m. at the Municipal Building.
- ii) **Historic Landmarks Commission** – Next Meeting on Wednesday November 17, 2021 p.m. at the Municipal Building. Minutes of the September 9, 2021 meeting were included in the packet.

- iii) **Weston Planning Commission** – Next Meeting on Wednesday November 10, 2021 p.m. at 4:30 p.m. at the Municipal Building.
- iv) **Boards of Parks and Recreation** - Next Meeting on Friday March 18, 2022 at 2:00 p.m. at the Municipal Building. Minutes of the September 17, 2021 meeting were in the packet.
- v) **Lewis County EDA Authority** – Next Meeting on Wednesday November 24, 2021 at 5:00 p.m. at the Court House.
- vi) **Board of Zoning Appeals** – Next Meeting on November 9, 2021 at 6:00 p.m.
- vii) **Code Appeals Board** – Next Meeting on Thursday 18, 2021 at 6:00 p.m. at the Municipal Building.
- viii) **Weston Central Neighborhood Watch** – Next Meeting January 2022. Minutes of the October 12, 2021 meeting were included in the packet.

B. Known Vacancies to be Filled:

- i) **Municipal Appeals Board (2)** - Chamber of Commerce will provide a member and Council will pick a member.
- ii) **Board of Zoning Appeals (1)** – The board can have an alternate, (2) members can be chosen.

Sanitary Board of Director Report: Director Dee Evans updated council on a work session with Lewis County Commission on the sludge removal and sludge management and a proposal for extension of the sewer system. We are working with WVU on a Covid testing program with the equipment they supplied to us it will automatically collect sludge, which we will mail to WVU. They will take the results and send us the findings if one area has more Covid than another area. The surrounding counties are doing the Covid testing as well. WSB repaired lines on Franklin Street and Delaware Avenue, and Charles Street. The Sanitary Department helped the Street Department raise manholes for paving. Report in packet.

Department Reports

Finance Report/Suttle & Stalnaker CPA Monthly Report: City Manager Stansberry provided council with the October 2021 Profit & Loss Budget Performance Report and the Profit & Loss Budget vs Actual. The balance sheet for October 2021 and the previous year comparison was included. Municipal Fees are down and attributed to the past due collection which are compiled together. The sales tax revenue for second quarter of the fiscal year came in \$7000 lower than average.

Street Department: Report in packet.

Police Department: Report in packet. Councilman Curtis asked if the police department received both vehicles. Chief Thomas informed that one vehicle is to get the lights and equipment put on in the next week, and the other vehicle we are in the process of a lease agreement.

Fire Department: Report in packet.

Building/Code/Zoning Report: Report in packet.



City Attorney Report: Attorney Bailey informed council of a FOIA request for receipts for a company doing research out of Michigan. Attorney Bailey stated the company doing the City Code update is going fine but no definite date when we will receive the product.

City Clerk Report: Report in packet.

City Manager Report: City Manager Stansberry thanked the city staff for all the different public activities that occurred in October. Anna Cardelli and Jamie Billman did a terrific job putting in extra hours for the Glass Museum ribbon cutting ceremony along with the Historic Landmarks Commission. Councilwoman Rogers requested a grant update to be included. City Manager Stansberry informed council for the REAP Grant, Taylor Construction & Salvage poured the concrete pad, and a 6-foot white vinyl fence will be put around the pad. The Siren Grant we have received all the funding. The Historic Landmarks Commission has several different grants, but we do not have all the details currently. When details received the council will be informed. The Columbia Club no action has been taken in the realm of the grant. The city is close to acquiring Columbia Club property. City Manager Stansberry had no update of the Department of Highways Transportation Alternative Grant. The EDA has a grant targeting recreational facility development with design and construction with a match of 20% to 25%. We have not applied for this grant but will get a proposal together for council to look at. The Blueprint Committee representative has a Recreation Planning Grant with no match. The city has not applied for this grant, City Manager Stansberry will get a proposal together for council to review for the city parks.

City Manager Stansberry attended audit training, and the city has the final approval for our audit contract. City Manager Stansberry attend pension training for the Municipal Pension Board, and he is in the process of getting our records better organized. Attorney Bailey and City Manager Stansberry are working together with the private landowner to get access for the 4th Street Bridge Project. The employees' vacation and sick time has been re-examined and the update is on the payroll system. Next month City Manager Stansberry will be getting the personnel handbook update as we've discussed in prior conversations. The police cruiser was approved in October and the paperwork is still processing, and the USDA Grants have been submitted.

Councilwoman Debbie Gump made a motion seconded by Councilman Bohan to **approve** all department reports. **Motion carried.**

Old Business:

Discussion on 4th Street Bridge Construction Over Polk Creek: City Manager Stansberry and Attorney Bailey are in the process of the purchase with the private landowner of a long-term easement to allow traffic to flow without using Spring Street. The construction date has not been given, they however do share our concerns having construction site open through the winter and then shut down. City Manager Stansberry felt they were leaning toward starting in the spring.

Dissolving URA Ordinance (Approval/Deny/Table): Councilman Curtis made a motion seconded by Councilwoman Rogers to **approve** to **suspend** the URA Ordinance by title only. City Clerk Judy Piercy read to suspend the URA Ordinance by title only. Councilman Curtis made a motion seconded by



Councilwoman Rogers to **approve suspending** URA Ordinance by title only. **(Roll call of votes, Councilwoman Rogers yea, Councilman Bohan yea, Councilwoman Gump yea, Councilman Curtis yea).** **Motion carried.**

New Business:

First Reading of On-Site Citations Ordinance (Approve/Deny/Table): Attorney Bailey asked at this time to **table** first reading of on-site citations ordinance more information is needed. Councilwoman Rogers made a motion seconded by Councilwoman Gump to **table** the first reading of on-site citations ordinance. **Motion carried.**

Veterans Day Parade Application (November 11, 2021 at 10:30 a.m.) (Approve/Deny/Table): Councilman Bohan made a motion seconded by Councilwoman Rogers to **approve** the Veterans Day parade application on November 11, 2021 at 10:30 a.m. **Motion carried.**

5K Run Application Stonewall Jackson Hospital (November 25, 2021) (Approve/Deny/Table): City Manager Stansberry spoke with Kevin Stalnaker about struggling with traffic control for this event. The event could be held inside the grounds of Jacksons Mill or the air strip. City Manager Stansberry asked to approve the application as a backup plan. Councilwoman Gump made a motion seconded by Councilwoman Rogers to **approve** 5K run application Stonewall Jackson Hospital on November 25, 2021. **Motion carried.**

Christmas Parade Application (A Hometown Holiday – Past, Present and Future on November 26, 2021) (Approve/Deny/Table): Councilwoman Gump made a motion seconded by Councilman Curtis to **approve** the Christmas parade application “A Hometown Holiday – Past, Present and Future” on November 26, 2021. **Motion carried.**

Miracle on Main Street Application (December 4, 2021) (Approve/Deny/Table): Councilwoman Gump made a motion seconded by Councilwoman Rogers to **approve** Miracle on Main Street on December 4, 2021. **Motion carried.**

Dump Truck Upfit Quotation (Approve/Deny/Table): City Manager Stansberry provided council with estimates for the dump truck upfit quotation with his recommendation of Switch-N-Go for \$25,893.00. Councilwoman Gump made a motion seconded by Councilman Curtis to **approve** the estimate for Switch-N-Go for \$25,893.00. **(Roll call of votes, Councilwoman Rogers yea, Councilman Bohan yea, Councilwoman Gump yea, Councilman Curtis yea).** **Motion carried.**

First Reading of Community Development Director Position (Approve/Deny/Table): City Manager Stansberry provided council with a 2021 ordinance creating position of community director position and a general statement of duties. Councilwoman Gump made a motion seconded by Councilman Curtis to **table** first reading of community development director position. **Motion carried.**

First Reading of 15 MPH Speed Limits on Crescent St/Alley (Approve/Deny/Table): Councilwoman Rogers made a motion seconded by Councilwoman Gump to have the first reading of 15MPH speed



limits on Crescent Street and Alley by title only. **(Roll call of votes, Councilwoman Rogers yea, Councilman Bohan yea, Councilwoman Gump yea, Councilman Curtis yea). Motion carried.** City Clerk read the first reading of 15MPH speed limits on Crescent Street and Alley by title only. Councilwoman Rogers made a motion seconded by Councilwoman Gump to **approve** the first reading of 15 MPH speed limits on Crescent Street and Alley by title only. **(Roll call of votes, Councilwoman Rogers yea, Councilman Bohan yea, Councilwoman Gump yea, Councilman Curtis yea). Motion carried.**

Visitors Section (5 Minute Time Limit): No one requested to speak.

Reports of City Council:

Mayor Harrison-Edwards: Mayor Harrison-Edwards submitted her monthly reports of meetings and activities.

Councilwoman Rogers – Ward I: Councilwoman Rogers attended all the committee meetings, commission meetings, and special session meetings. Councilwoman Rogers contacted Region 7 inquiring about additional grants for sidewalks, beautification projects, street paving, repair bridge lighting and pier removal at the 4th Street Bridge. Councilwoman Rogers will keep everyone informed of the grants as they are found.

Councilman Bohan – Ward II: Councilman Bohan shared a lesson he learned going trick or treating. The lesson was how you present something can obtain unity among your local people by approaching them in a certain manner.

Councilwoman Gump – Ward III: Councilwoman Gump commented that a lot of things were approved that dealt with our community and it's a great thing for community involvement. Councilwoman Gump attended the safety fair, crossroads exhibit at the museum ribbon cutting ceremony. Councilwoman Gump organized all high school students to attend, which gave the students the opportunity to gauge history and how it was at the turn of the century. Councilwoman Gump thanked the Historic Landmarks Commission for bringing it to our community. It was great to have trick or treating, safety fair, Christmas parade, all these activities we tabled last year because of Covid. It is great to have a normal season this year.

Councilman Curtis – Ward IV: Councilman Curtis thanked the citizens and employees for attending the meeting. Councilman Curtis has been working with the citizens in his neighborhood with all the drug issues and the breaking and entering. The neighborhood is working together watching out for each other's house when they are they are not home. Councilman Curtis thanked Gene Edwards for the making it possible for the lights on North Main Avenue bridge. Councilman Curtis stated that the people are noticing the changes we are making.

Adjournment:

Councilman Curtis made a motion seconded by Councilwoman Rogers to **adjourn** at 7:57 p.m. **Motion carried.**



Attest

Mayor Kim Harrison-Edwards

City Clerk, Judy Piercy



Weston City Council
Special Session
November 10, 2021
Minutes

Present: Mayor Kim Harrison-Edwards, City Attorney Brian Bailey, Councilwoman Sherry Rogers, Councilwoman Debbie Gump, Anna Cardelli, Jamie Billman, Brock Perkins, Steve Hayes, Dan Farrell and Larry Bush. Via phone included City Manager Nate Stansberry, Ashley Montgomery, W. T. Weber III, Dee Evans, and Mike Starett.

Call to Order: Mayor Harrison-Edwards called the meeting to order at 6:00 p.m.

Pledge of Allegiance: Mayor Harrison-Edwards asked all to stand for the Pledge of Allegiance.

Old Business:

Discussion on the 4th Street Bridge Construction over Polk Creek: City Manager Stansberry gave an update and stated that work may be delayed.

Second Reading of 15 MPH Speed Limit on Crescent Street/Alley (Approve/Deny/Table):

Councilwoman Rogers made a motion seconded by Councilwoman Gump to **approve** the second reading of the 15 MPH Speed Limit on Crescent Street/Alley Ordinance, by title only. **Motion carried.** City Attorney Bailey, in absence of City Clerk, read the 15 MPH Speed Limit on Crescent Street/Alley by title only. Councilwoman Rogers made a motion and seconded by Councilwoman Gump to **approve** the second reading of the 15 MPH Speed Limit on Crescent Street/Alley Ordinance by title only. **Motion carried.** The first reading by title only was November 1, 2021. The approval of this second reading by title only enacts the 15 MPH Speed Limit on Crescent Street/Alley as of November 10, 2021.

Application for Arts Culture /History Grant Fiscal Year 2022 Amount of \$1188.00

(Approve/Deny/Table): Councilwoman Rogers made a motion seconded by Councilwoman Gump to **approve submission** for a grant application to the WV Division of Culture and History for a Fiscal Year 2022 Grant in the amount of \$1,188.00. **Motion carried.**

Anna Cardelli made a presentation to Council for approval on the submission of the following grants.

- National Endowment for the Humanities \$15,000 requiring no match. Grant funds would be used for programming and equipment.
- PAWV & SHPO Grant \$25,000 for masonry workshop for Bank Alley, brick house and possible other spaces. If awarded, SHPO would provide us with the match.
- Institute for Museum and Library Services \$5,000 would be used for programming and modular exhibits at Weston Cultural Center. The grant requires a \$2,500 match.

Councilwoman Rogers moved to **approve** the submission of the National Endowment for the Humanities Grant in the amount of \$15,000, the PAWV & SHPO Grant in the amount of \$25,000 and the Institute for Museum and Library Services in the amount of \$5,000, requiring a \$2,500 match. **Motion carried.**



Discussion of Community Development Director Position: No update was given.

New Business

ARPA Funding/Weston Sanitary Board: Dan Farrell and Steve Haynes from Thrasher Engineering were on hand to discuss a request for funding to aid in the sludge removal at the Weston plant. Council will meet at a later date to make a decision on funding.

Award Demolition of Vacant Structures to Envirolean LLC., or AMI/Safe Co., (Approve/Deny/Table):

Councilwoman Rogers made a motion seconded by Councilwoman Gump to **accept** the bid from Envirolean LLC., in the amount of \$9,800 for the demolition of the structure at 251 S. Main Avenue.

Motion carried.

Councilwoman Rogers made a motion seconded by Councilwoman Gump to **accept** the bid from Envirolean LLC., in the amount \$11,050 for the demolition of the structure at 241 S. Main Avenue.

Motion carried.

Councilwoman Rogers made a motion seconded by Councilwoman Gump to **accept** the bid from Envirolean LLC., in the amount of \$12,300 for the demolition of the structure at 270 High Street. **Motion carried.**

Councilwoman Rogers made a motion seconded by Councilwoman Gump to **accept** the bid from AMI/Safe Co., in the amount of \$10,000 for the demolition of the structure at 140 Mulberry Street.

Motion carried.

Public Comment: None

City Manager Update: City Manager Stansberry stated that they are working on property acquisition of the Columbia Club. An ensued brief discussion on establishing a formal relationship with the architect on this project. Council will remain updated on paving issues.

Adjournment: Councilwoman Gump made a motion seconded by Councilwoman Rogers to **adjourn** at 7:45 p.m. **Motion carried.**

Attest:

Mayor, Kim Harrison-Edwards

City Clerk, Judy Piercy



Weston City Council
Special Session
November 15, 2021
Minutes

Present: Mayor Kim Harrison-Edwards, Councilpersons Sherry Rogers, Randy Bohan, Debbie Gump, Herb Curtis. Building/Code/Zoning Enforcement Officer, Sanitary Board of Director Dee Evans, and Dave Gump. Via Zoom City Manager Nate Stansberry, City Attorney Brian Bailey, Ashley Montgomery.

Call to Order: Mayor Harrison-Edwards called the meeting to order at 6:00 p.m.

Pledge of Allegiance: Mayor Harrison-Edwards asked all to stand for the Pledge of Allegiance.

Public Comment: None

Old Business:

Consideration of Resolution for ARPA Funding for Weston Sanitary Board (Approve/Deny/Table): Councilwoman Rogers made a motion seconded by Councilman Bohan to enter executive session at 6:10 p.m. **Motion carried.** Councilwoman Gump made a motion seconded by Councilman Bohan to exit executive session at 6:30 p.m. **Motion carried.** Councilman Bohan made a motion seconded by Councilwoman Rogers to **table** the consideration of resolution for ARPA Funding for Weston Sanitary Board until more information at the work session with Lewis County Commission. **Motion carried.**

New Business: None

City Manager Update: City Manager Stansberry informed council that he will be returning to work on Friday, November 26, 2021 as stated by the Lewis County Health Department from Covid. City Manager Stansberry has been in contact with Cooper Asphalt about starting to pave, and possibly soon they will start weather permitting.

Adjournment:

Councilman Bohan made a motion seconded by Councilwoman Rogers to adjourn at 7:15 p.m. **Motion carried.**

Attest

Mayor, Kim Harrison Edwards

City Clerk, Judy Piercy



Weston City Council
Special Session
November 30, 2021
Minutes

Present: Mayor Kim Harrison-Edwards, Councilpersons Sherry Rogers, Randy Bohan, Debbie Gump, Herb Curtis. City Manager Nate Stansberry, City Clerk Judy Piercy, City Attorney Brian Bailey, Chief Josh Thomas, Building/Code/Zoning Enforcement Officer Mike Starrett, Sanitary Board of Director Dee Evans.

Call to Order: Mayor Harrison-Edwards called the meeting to order at 7:12 p.m.

Pledge of Allegiance: Mayor Harrison-Edwards asked us to stand for the Pledge of Allegiance.

Public Comment: No one to speak

Old Business:

ARPA Funding for Weston Sanitary Board (Approve/Deny/Table): City Manager Stansberry expressed the work session with the Lewis County Commission went well and appreciated the Sanitary Board for compiling information and figures. City Manager Stansberry provided and discussed with council the spread sheets for sludge removal, and different phrases of the project. Brock Perkins from the Sanitary Plant explained the process of the drying beds and that it would be the less expensive way to process sludge. Brock stated that no matter what system used the sludge needs removed now. The tanks are full and cannot hold anymore. Councilman Bohan asked if sludge removal was in the Sanitary Board budget each year. City Manager explained phase one was only going to be a short-term fix and a long-term fix is needed. Both City Manager Stansberry and Councilman Bohan asked for a plan on how the money will be used for sludge removal. Councilwoman Rogers made a motion seconded by Councilwoman Gump to adopt a resolution to contribute \$350,000 to the Weston Sanitary Board for sludge removal. City Manager Stansberry stated as a council you have the right to earmark a portion of the money to be designated to be put back for future sludge removal. Mayor Harrison-Edwards asked Councilwoman Rogers if she would like to rescind her motion. Councilwoman Rogers stated she did not. **(Roll call, Councilwoman Rogers yea, Councilman Bohan nay, Councilwoman Gump yea, Councilman Curtis yea).** **Motion carried.**

New Business:

Municipal Home Rule Report (Approve/Deny/Table): City Manager Stansberry provided council with the Municipal Home Rule Program 2021 Progress Report. During the discussion of the program Mayor Harrison-Edwards pointed out rewording under Payment and Selection of Auditors. Councilwoman Rogers made a motion seconded by Councilman Bohan to **approve** the Municipal Home Rule Program 2021 pending corrections. **Motion carried.**

Demolition Bid Reconsideration (Approve/Deny/Table): City Manager Stansberry provided council with a copy of the bid packets returned by the contractors. As council looked over the bid packet discussion



of the properties for the demolition were to be together as one bid or individual. Council thought that changes need made to the form for more clarity. Building/Code/Zoning Enforcement Officer Mike Starett stated a change was in the works. Councilman Bohan made a motion seconded by Councilman Curtis to **approve** the demolition bid to remain as awarded. **(Roll call, Councilwoman Rogers nay, Councilman Bohan yea, Councilwoman Gump yea, Councilman Curtis yea). Motion carried.**

Bonuses/Incentives for Employees (Approve/Deny/Table): City Manager Stansberry provided council with an information sheet of full-time employees at \$200 and part time employees at \$100 each for incentives. Councilwoman Rogers made a motion seconded by Councilman Curtis to **approve** incentives for employees. **(Roll call, Councilwoman Rogers yea, Councilman Bohan yea, Councilwoman Gump yea, Councilman Curtis). Motion carried.**

City Manager Stansberry requested for council to go into executive session. Councilwoman Gump made a motion seconded by Councilwoman Rogers to enter executive session at 8:50 p.m. Councilwoman Rogers made a motion seconded by Councilwoman Gump to exit executive session at 9:04 p.m.

City Manager Update:

City Manager Stansberry tabled his update until next meeting.

Adjournment:

Councilwoman Gump made a motion seconded by Councilwoman Rogers to adjourn at 9:05 p.m.

Attest

Mayor, Kim Harrison-Edwards

City Clerk, Judy Piercy

5. Presentations

ATTENTION CITY OF WESTON RESIDENTS

The City Council for the City of Weston, West Virginia, meeting in regular session of Monday, the 6th of December 2021, at 6:00 p.m., in the Lewis County Court House, 117 Center Avenue, Weston WV will conduct a public hearing on the following:

The USDA has received an application for federal assistance from the City of Weston. The proposed project consists of purchasing two police cruisers for the City of Weston's police department. This notice also is to inform of a public meeting to be held on December 6, 2021, at 6:00 p.m. The purpose of this meeting is to provide information to the public regarding this project and to comment on economic and environmental impacts, service area, or alternatives to the project.

The USDA requires that the general public be given the opportunity to respond in an open forum to the proposed uses of said grant funds as outlined in the application. At the public hearing, any interested citizen may appear and be heard.

6. Receive and File Reports of City Boards, Commissions, and Outside Agencies

UNITED STATES OF AMERICA
FEDERAL ENERGY REGULATORY COMMISSION

Atlantic Coast Pipeline, LLC
Eastern Gas Transmission and Storage, Inc.

Docket Nos. CP15-554-009
and CP15-555-007

NOTICE OF REVISED SCHEDULE FOR ENVIRONMENTAL REVIEW OF THE
ATLANTIC COAST PIPELINE RESTORATION PROJECT
AND
SUPPLY HEADER PROJECT RESTORATION PROJECT

(November 19, 2021)

This notice identifies the Federal Energy Regulatory Commission staff's revised schedule for the completion of the supplemental environmental impact statement (sEIS) for Atlantic Coast Pipeline, LLC's (Atlantic) Atlantic Coast Pipeline Restoration Project and Eastern Gas Transmission and Storage, Inc.'s (EGTS) Supply Header Restoration Project. The first notice of schedule, issued on May 4, 2021, identified November 19, 2021, as the final sEIS issuance date. However, we are modifying the issuance date based on comments received on the draft sEIS to include additional analyses of impacts on environmental justice communities in the sEIS that will assist the Commission in its decision-making process.

Schedule for Environmental Review

Issuance of the Notice of Availability of the final sEIS
90-day Federal Authorization Decision Deadline

December 17, 2021
March 17, 2022

If a schedule change becomes necessary, an additional notice will be provided so that the relevant agencies are kept informed of the project's progress.

Additional Information

In order to receive notification of the issuance of the sEIS and to keep track of all formal issuances and submittals in specific dockets, the Commission offers a free service called eSubscription. This can reduce the amount of time you spend researching proceedings by automatically providing you with notification of these filings, document summaries, and direct links to the documents. Go to <https://www.ferc.gov/ferc-online/overview> to register for eSubscription.

Additional information about the Project is available from the Commission's Office of External Affairs at (866) 208-FERC or on the FERC website (www.ferc.gov). Using the "eLibrary" link, select "General Search" from the eLibrary menu, enter the

selected date range and "Docket Number" excluding the last three digits (i.e., CP15-554; CP15-555), and follow the instructions. For assistance with access to eLibrary, the helpline can be reached at (866) 208-3676, TTY (202) 502-8659, or at FERCOnlineSupport@ferc.gov. The eLibrary link on the FERC website also provides access to the texts of formal documents issued by the Commission, such as orders, notices, and rule makings.

Kimberly D. Bose,
Secretary.

For Note & Council

KAL

-Lewis-Upshur LEPC Meeting Minutes

The Meeting was called to order 12:01 by D. Burnside in Lewis County.

The Pledge of Allegiance and Moment of Silence was led by D. Burnside.

The floor was given to

Members Present: See attached sign-in sheet.

MINUTES APPROVAL

Minutes were sent out in August (add Kim Harrison)

. Minutes were approved by acclimation

TREASURES REPORT

The treasurer's report was accepted

Chairman's Comments: Visiting a list of sites that have not complied we should be able to access the state website to get The critical site and the Tier 2 forms. D.

Grant Updates: (See New business)

.

Committee Reports: We need volunteers for the committees

Membership: Nothing to report

Public Education/Information: Nothing to report

Annual Exercise Planning Team (HSEEP): Glen Davis volunteers.

Bylaws: Nothing to report.

Hazard Assessment & Planning: Nothing to report

Tier II Reports: Reporting season has just ended

Off Site Emergency Response Plans: J Farry has been taking care of that. Lately.

Old Business: Nothing To Report

New Business: D Burnside has received information from Carrie W. on the new grant application we are looking at having 3,000 per county available for that grant. Lisa Paxton has been working with D. Burnside on these grants. We need to plan and have a public meeting. Which is a performance goal of the grant? Our LEPC bylaws were approved in 2012, our comprehensive emergency response plan should be updated annually, and has not been. We need to have an annual membership application approved. Even if you have done an application in the past, the list of people that are official voting persons to be updated.

J. Gum will resend that application. If you need to know categories they are on our website.

FOIA process was discussed.

Designate a person to be assigned as our county coordinator

Minutes in meetings are needed for the grand paperwork. October first is deadline for application but not all paperwork.

There is an HMEP grand application coming to us which we can fill out. They would like to see a new cycle of a commodity flow study and hazards analysis.

Possibility of using VIPS (Steve Wycoff is the lead) There will be a CERT class the end of the month.

Lewis County had 3 positions.

Dr. Reed suggested possibly students to help.

J. Farry willing to coordinate in Upshur County

J. Gum in Lewis County

The OEM budget in Upshur County had \$2000 in the budget for LEPC as well as funding from these and previous grants. There is not anything in FY2022 for it, if by March first it can be considered for FY 2023 (was under hazmat supplies)

Membership Comments:

Vacancies in our bylaws. Executive committee will meet to elect officers to finish out the remainder of 2021

there is vacancy of Upshur county coordinator and Chairman

James Gum volunteers for co-chair typically the county coordinators are the OEM Directors.

Carrie W. accepts that role for Upshur county coordinator

J. Reed has volunteered to be on the executive committee. D. Burnside volunteers for education for the next meeting.

D. Cutright, Most interested because of being situationally aware so that we can better respond to them.

Dr. Reed. Interest in what goes on in the community.

S. Nolte has learned a lot and it helps with his concern of what is going on in our community.

Kim Harrison feels it's important for the city of Weston to have consistent representation, and everyone staying informed.

Glen Davis, Captain of Buckhannon fire and Upshur county FD and wants to be able to coordinate for everyone.

J. Farry Private citizen is concerned with awareness and preparedness. And have ability to help mitigate any disasters we have

Edsel Smith. Has been around for a long time fire marshal's office suggested that he be volunteer. He has a lot of experience In hazmat.

Shannon W. has served in the 911 center the CERT etc.

Steve Money penny

James Gum as a 911 director seeing what we are sending out there, and what is there, and as an OEM director seeing what is out there in the community

Carrie W.

Serving dual roles as county administrator as DHSEM director is gathering information to responding in our community the LEPC is to thrive. Both counties need to work together.

D. Burnside, officially the amateur radio services for years, and has served with the LEPC he sees great reasons to participate in this organization. Wants to make sure his family and friends in emergency services help keep the community safe and looks forward to the future things to come.

Meeting is adjourned at 12:55 PM

Executive committee meeting.

J Gum nominates D Burnside Steve seconds.

D. Burnside nominates J Gum for co chair

J gum nominates Carrie W S. Whited seconds all in favor Carrie will be coordinator.



CITY OF WESTON BOARDS/COMMISSIONS

APPLICATION

Name: Ray Smith

Address: 346 Market Place Mall

Weston, WV 26452

Telephone: (Home) 304-269-2608 (Cell) 304-695-0488

Please mark each board/commission you wish to be considered.

Planning Commission

Weston Fine Arts Committee

Historical Landmarks Commission

Fairs and Festivals Committee

Board of Parks and Recreation

Municipal Appeals Board

Board of Zoning Appeals

Weston Cemetery Board

Please provide a detailed summary of your experience, education and/or training that would contribute to the board and/or commission you are requesting appointment:

Executive Director of Lewis County Chamber of Commerce

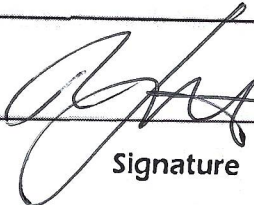
Signature

12/3/21

Date

This application will be reviewed by the City of Weston Council. You will be contacted after the Council has rendered a decision. We appreciate your interest in assisting your local government.

**City of Weston Committee and/or Commission
Application**

Name: Kristen Bailey

Address: 350 Sauls Run Rd
Weston WV 26452

also own property at 204 High Street, Weston

Telephone: (home) 304-838-1339

(cell) _____

Email address: kwilkes@mix.wvu.edu

If you are currently sitting on any City Committees and/or Commission please list them: _____

Please mark each committee and/or commission you wish to be appointed to

Planning Commission

Weston Fine Arts Committee

Historical Landmarks Commission

Fairs and Festival Committee

Parks and Recreation

Zoning Board

URA

Please give a detailed summary of your experience, education and/or training that would contribute to the committee and/or commission you are requesting to be appointed to:

Please see attached

Signature

11/16/21
Date

This application will be reviewed by the City of Weston Council. If you are picked to be appointed to the committee and/or commission you selected the City of Weston will contact you.

KRISTEN L. BAILEY

350 Sauls Run Rd, Weston, WV 26452 | 304-838-1339 | klwilkes@mix.wvu.edu

WORK HISTORY

Graduate Instructor, West Virginia University

Fall 2021

Currently teaching two online courses, including one section of US History survey course 153 (1865 to present), and one section of History 259 (Reconstruction, Gilded Age, and Progressive Era), independently preparing all lecture notes, exams, and other course material. Utilized eCampus, Zoom, and Mediasite resources to build online courses for this semester. Independently monitoring more than sixty students, completing all grading and reporting required by WVU.

Project Manager, *Timber/Timbre* cultural programming

Summer 2021-Fall 2021

Organized and directed cultural programming in support of the *Timber/Timbre: Falling Trees and Rising Voices* traveling museum exhibit. Contacted and scheduled monthly events at Cass Scenic Railroad State Park, including exhibition of tools of the timber camps, a roundtable discussion of the history and music of the region, and a lecture/performance of timber camp songs. Collaborated with local history stakeholders to enhance overall project. Coordinated local events for Marlinton, WV, including a presentation of library and digital resources for local history, and a performance of local folk musicians. Coordinated food and lodging and arranged for publicity for events.

Graduate Research Assistant, Kate Kelsey Staples, Department Chair (WVU)

Spring 2021

Developed an undergraduate Public History course for potential future offerings at WVU. Using the National Parks Service "Teaching with Historic Places" as a guideline, and following both department and WVU course requirements, built a cohesive syllabus to complement WVU Public History course offerings.

Developed a graduate student survey to explore the department's use of pedagogue, teaching practicum, and graduate teaching assistant training. Used Qualtrics system to build a survey from which the department could elicit quality responses from which to enhance their GTA trainings.

Graduate Research Assistant, Danielle Petrak, Curator
Royce J. & Carolyn B. Watts Museum

Spring 2021

Conducted research into political cartoons centered around the West Virginia Mine Wars for a future exhibit, sourcing content from multiple digital sites, including HathiTrust, Chronicling America, and Newspapers.com. Worked closely with the museum curator to source subject matter to fit the project.

- Graduate Instructor, WVU
Fall 2020
Taught two sections of US History survey course 153 (1865 to present), independently preparing all lecture notes, exams, and other course material, independently monitoring more than forty students, completing all grading and reporting required by WVU.
- Graduate Research Assistant, Kentucky Historical Society
February 2020-February 2021
Civil War Governors of Kentucky (CWGK) Digital Documentary Edition
Provided annotated historical research for CWGK documents, identifying each person, place, organization, and geographic feature within selected primary source documents assigned from the Civil War Governors of Kentucky digital project. Working entirely remotely, utilized multiple digital research resources (including Ancestry.com, Fold3, Hathitrust, Chronicling America) to construct comprehensive research using Mashbill to support the Omeka digital platform. Collaborated regularly with a team via Zoom and Slack platforms to discuss prospective lines of research and worked within an established digital platform to adhere to policies and procedures for research.
- Graduate Research Assistant, Danielle Petrak, Curator
Summer 2020
Royce J. & Carolyn B. Watts Museum, *Timber/Timbre* traveling museum exhibit project
Conducted research, writing, and design development of a traveling exhibit which explored the impact of the timber industry on the cultural life in the Allegheny Highlands and Greenbrier River Valley of West Virginia. Research included examination of audio music, transcribed lyrics, personal diaries, historic photographs, and academic works to compile exhibit content.
- Graduate Research Assistant, Jason Phillips PhD
Fall 2019-Spring 2020
Conducted independent and guided research into rifle clubs in post-bellum South Carolina. Research included developing an Excel database of rifle club members, with associated affiliations, and locating future research avenues in archives. Provided Dr. Phillips with extensive annotated research to accompany primary source documents that included rifle club minutes and histories.
- Graduate Research Assistant, Melissa Bingmann PhD,
Fall 2019-Spring 2020
Conducted research and collaborated with multiple stakeholders in Pocahontas County, WV in contemplation and preparation of major grant submission to the West Virginia Humanities Council for a collaborative project to highlight the history of timber and music in Pocahontas County, WV. Prepared material to guide student research for physical exhibit and programming centered on the history of the music of the timber camps in Pocahontas County.
- Internship/Fellowship, Pocahontas County project
Summer 2019
Research for WVU grant proposal *Hardwood and Harmony* (later renamed *Timber/Timbre*)
Organization and collections inventory at the Pearl S. Buck Birthplace and the Cass Scenic Railroad Park Museum (created Excel databases for both sites)

Graduate Instructor, West Virginia University

Taught US History survey course 152 (founding to 1865) and 153 (1865 to present), independently monitored more than forty students, completing all grading and reporting required by WVU.

Spring 2018 – Summer 2019

Bailey, Stultz, Oldaker and Greene PLLC
Case Manager and Paralegal

September 1996 to August 2018

GRANTS

West Virginia Humanities Council Grant

Participated in team writing of grant application of more than \$15,000 to fund museum exhibit development, research, and writing, and to fund cultural programming which I designed and organized.

Fall 2020-Fall 2021

West Virginia University Office of Graduate Education and Life

Awarded a fellowship to fund additional research for the Watts Museum's development of the *Timber/Timbre: Falling Trees and Rising Voices — Music and Logging in West Virginia, 1880-1930*

Summer 2020

West Virginia University Office of Graduate Education and Life

Paid Internship/Fellowship for Pocahontas County, which was used to catalog and record museum inventory at the Cass Museum and the Pearl S. Buck Birthplace

Summer 2019

EDUCATION

West Virginia University

PhD Student (post-comps, prospectus development); fields include US History, 1840-1898; Appalachian History; Public History; World History

August 2018 to present

West Virginia University

MA, US History 1840-1898 (major field), Public History (minor field)

May 2018

Thesis Title: "All Aboard: The Influence of the Baltimore and Ohio Railroad on Sectionalism and Statehood in West Virginia,"

ARTICLES

- "Brave Shanty Boys: The Songs of Timber Workers and Community In Pocahontas County, West Virginia," in final editing for upcoming publication by the *Journal of Appalachian Studies*.
- "All Aboard: The Influence of the Baltimore and Ohio Railroad on Sectionalism and Statehood in West Virginia," published by *West Virginia History: A Journal of Regional Studies*, New Series, Volume 13, Number 2, Fall 2019.

- "Falling Run – A Bridge to the Future." Published by the Monongalia Historical Society's *Papers and Proceedings*, December 2017.

CONFERENCE PRESENTATIONS

Ohio Valley History Conference at the Kentucky Historical Society June 2019
Presented original research "Logan County's Antebellum Petitions and the West Virginia Statehood Process"

Microhistories of the Civil War Era,
Virginia Center for Civil War Studies at Virginia Tech May 2019
Presented original research "All Aboard: The Influence of Baltimore and Ohio Railroad on Sectionalism and Statehood in West Virginia" in the panel "Grounding Microhistory"

West Virginia University History Graduate Student Association conference April 2019
Presented original research "All Aboard: The Influence of Baltimore and Ohio Railroad on Sectionalism and Statehood in West Virginia," receiving first place in panel.

MEMBERSHIPS

American Association for State and Local History
American Historical Association
Organization of American Historians
Phi Sigma Theta National Honor Society
Society of Civil War Historians

7. and 8. Sanitary Board and Department Head Reports

**WESTON SANITARY BOARD
171 MAIN AVENUE
WESTON, WV 26452
(304)269-1300**

**MONTHLY REPORT
December 6, 2021**

PROJECT UPDATE

- Negotiations continue with landowners in the Turnertown area regarding issues that have come about as a result of the project. A couple of these have been resolved by discussions with Board Members and or WSB employees doing some of the needed work to satisfy the landowners.
- Follow-up letter sent to Land Owner regarding settlement on negotiations.
- Work Session with County Commission and City Council took place on Tuesday November 30 at 6:00pm to discuss the possibility of both parties contributing financially to the Sludge Removal Project. This Phase I of the project as well as Phase II, the permanent/ongoing Sludge Removal Project was discussed at length. City Council met immediately after this work session in Special Session with the Action Item of whether or not City Council would financially participate in this project. After much discussion by both parties present, City Council and WSB, the City Council Members passed a resolution by 3-1 vote to contribute 350,000 to this project. County Commission are scheduled to act on the same item at their regular weekly meeting on Tuesday December 7, 2021.

PLANT REPORT

- Insulated piping at Headworks
- Winterized all equipment, trailered Power Washer, all other pressure washers
- Installed 160 New UV Bulbs, 12 New Circuit Boards
- Repaired Heater Breaker at the Plant
- Daily Lab samples taken and transported to lab.
- Weekly UV and Filter Cleaning & Maintenance
- Discussions with Landowners about sludge land applications
- Continue working with EPA, Thrasher, Attorney, Director, Chairperson regarding CAP
- Continue Program with WVU on Covid Testing/Plant Influent
- Safety Training with Assured Partners
- Discussions with Region VII regarding Sludge Removal Project Phase I and II—Procurement and Funding

COLLECTION

- New Taps at 466 Jacob Street, 530 Valley Chapel Road
- Tie-In Taps at Fire School
- Ran over 600' of pipe for Taps

- Repaired line @ Cemetery Street—Water Company broke line
- Preparing for 2 more new taps—Butchers Lane and Barber Shop behind Wendy's

PUMP STATIONS

- Cummins in for Generator Maintenance
- Repaired Transducer Issues at Jackson Mill
- Pulled Pumps at Fire School, Hickory House, Kincheloe, Dancers
- Vac Truck for Kincheloe and Cemetery
- Call Outs for Kincheloe and Hickory House
- Filled all Generators with Diesel and Serviced

JET CALLS

- 19 Jet Calls 10 Customer 9 Mains

OFFICE-Director

- Work Sessions and Meetings with County Commission
- Work Sessions and Meetings with City Council
- Discussions with Region VII regarding Phase I and Phase II of Sludge Removal
- Discussions with Board Members and Land Owners regarding Land Applications of Sludge
- Discussions with WVU and Engineering firm regarding new water and sewer lines
- Meeting with EPA, DEP, regarding progress and future planning
- Safety Training with Assured Partners
- Working on Collections of Final Customer past due accounts
- Training with Software for Customer Statement Email Option
- Weekly Department Head Meetings with City Manager
- Monthly Adjustments
- A/P, Payroll, Reporting
- Worked with Accountant in House on Annual PSC Report
- Worked with Accountant Office on Project Close-out Accounting Reports
- Audit Procurement Complete-Waiting on Approved Contract from State Auditor
- Daily/Weekly conversations with Engineers/Special Council regarding project
- Continued negotiations with MSW on Building Rental
- Working with customers to obtain assistance from Mountaineer Rental for past due WSB Bills

Dee Evans, Director

**CITY OF WESTON
Profit & Loss Budget Performance**

November 2021

	Nov 21	Budget	Jul - Nov 21	YTD Budget	Annual Budget
Ordinary Income/Expense					
Income					
wv coal severance	0.00	0.00	0.00	0.00	0.00
301.000 · PROPERTY (AD VALOREM) TAXES	10,845.82	33,256.17	236,997.28	166,280.81	399,074.00
302.000 · TAX PENALTIES & INTEREST	973.77	416.67	7,555.47	2,083.31	5,000.00
303.000 · GAS & OIL SERVANCE TAX	0.00	479.17	7,291.34	2,395.81	5,750.00
304.000 · EXCISE TAX ON UTILITIES	65,496.15	26,666.67	138,197.10	133,333.31	320,000.00
305.000 · B & O TAX	44,016.38	37,500.00	268,110.56	187,500.00	450,000.00
306.000 · WINE & LIQUOR TAX (WLP)	0.00	4,916.67	28,927.24	24,583.31	59,000.00
307.000 · ANIMAL CONTROL TAX	70.20	83.33	823.50	416.69	1,000.00
314.000 · Sales Tax Revenue	0.00	47,916.67	323,060.31	239,583.31	575,000.00
320.000 · FINES, FEES & COURT COSTS					
Court	0.00		169.64		
320.000 · FINES, FEES & COURT COSTS - Other	268.00	416.67	3,247.00	2,083.31	5,000.00
Total 320.000 · FINES, FEES & COURT COSTS	268.00	416.67	3,416.64	2,083.31	5,000.00
321.000 · PARKING VIOLATIONS	0.00	41.67	160.00	208.31	500.00
325.000 · LICENSES	780.00	875.00	11,805.00	4,375.00	10,500.00
326.000 · PERMIT FEES	3,190.00	0.00	5,729.50	0.00	0.00
327.000 · MISC. PERMITS	0.00		25.00		
328.000 · FRANCHISE FEES	3,058.20	3,125.00	12,306.24	15,625.00	37,500.00
330.000 · IRP FEES	5,338.97	2,916.67	59,162.85	14,583.31	35,000.00
336.000 · CEMETERY REVENUES	0.00	83.33	0.00	416.69	1,000.00
341.000 · MUNICIPAL SERVICE FEES	12,216.79	23,500.00	256,151.83	117,500.00	282,000.00
342.000 · PARKING METER REVENUES	0.00	83.33	0.00	416.69	1,000.00
343.000 · OFF STREET PARKING	240.00	250.00	840.00	1,250.00	3,000.00
344.000 · COLLECTIONS DELINQUENT ACCTS					
DELINQUENT MUNICIPAL	0.00		47.22		
344.000 · COLLECTIONS DELINQUENT ACCTS - ...	0.00	0.00	0.00	0.00	0.00
Total 344.000 · COLLECTIONS DELINQUENT ACCTS	0.00	0.00	47.22	0.00	0.00
352.000 · FIRE PROTECTION FEE	0.00	833.33	0.00	4,166.69	10,000.00
361.000 · CHARGES FOR SERVICES	0.00	0.00	0.00	0.00	0.00
367.000 · Other Grants					
367.005 · CARES ACT	0.00		851,115.04		
367.000 · Other Grants - Other	0.00	0.00	507.56	0.00	0.00
Total 367.000 · Other Grants	0.00	0.00	851,622.60	0.00	0.00
376.000 · VIDEO LOTTERY/GAMBLING INCOME					
376.001 · GREENBRIER DISTRIBUTION INCOME	31.03		178.05		
376.002 · TABLE GAMES DISTRIBUTION INCOME	936.20		4,542.69		
376.000 · VIDEO LOTTERY/GAMBLING INCOME - ...	0.00	625.00	0.00	3,125.00	7,500.00
Total 376.000 · VIDEO LOTTERY/GAMBLING INCOME	967.23	625.00	4,720.74	3,125.00	7,500.00
381.000 · REIMBURSEMENTS	3,488.82	8,507.00	14,317.07	42,535.00	102,084.00
382.000 · Refunds and Rebates	0.00	125.00	799.80	625.00	1,500.00
383.000 · SALE OF FIXED ASSETS	0.00	0.00	1,183.00	0.00	0.00
389.000 · ACCIDENT REPORTS/INCIDENT	420.00	166.67	1,830.00	833.31	2,000.00
397.000 · Video Lottery (LVL)	1,877.18	1,666.67	9,904.90	8,333.31	20,000.00
399.000 · MISCELLANEOUS REVENUE	40.00	0.00	80.00	0.00	0.00
436.218 · CODE ENFORCEMENT POSTAGE	0.00		-230.46		
Total Income	153,287.51	194,450.69	2,244,834.73	972,253.17	2,333,408.00
Gross Profit	153,287.51	194,450.69	2,244,834.73	972,253.17	2,333,408.00
Expense					
103.0 · Salaries	0.00		0.00		
104.0 · Payroll Taxes	0.00		0.00		
409.103 · MAYOR'S OFFICE OFFICIALS SALARIE	0.00	500.00	0.00	2,500.00	6,000.00
409.104 · MAYOR'S OFFICE PAYROLL TAXES	0.00	38.25	0.00	191.25	459.00
410.103 · CITY COUNCIL OFFICIAL'S SALARIES	1,300.00	800.00	6,500.00	4,000.00	9,600.00
410.104 · CITY COUNCIL PAYROLL TAXES	99.45	61.17	497.23	305.81	734.00
410.341 · CITY COUNCIL MATERIALS & SUPPLY	0.00	41.67	100.00	208.31	500.00
412.103 · CITY MANAGER WAGES	2,932.80	5,416.67	17,683.28	27,083.31	65,000.00
412.104 · CITY MANAGER-PAYROLL TAXES	215.12	414.42	1,305.63	2,072.66	4,973.00
412.105 · CITY MANAGER'S EMP INSURANCE	0.00	0.00	0.00	0.00	0.00
412.106 · CITY MANAGER RETIREMENT EXPENSE	0.00	0.00	0.00	0.00	0.00
412.110 · CITY MANAGER'S WORKERS COMP	0.00	0.00	0.00	0.00	0.00
412.211 · CITY MANAGER TELEPHONE	201.58		806.44		
412.220 · CITY MANAGER ADV. / LEGAL	0.00	41.67	0.00	208.31	500.00
412.221 · CITY MANAGER TRAINING AND ED	135.00	41.67	135.00	208.31	500.00
412.222 · CITY MANAGER DUES / SUBSCRIP	0.00	41.67	50.00	208.31	500.00
412.341 · CITY MANAGER'S SUPPLIES & MATER	0.00	83.33	181.01	416.69	1,000.00
413.237 · TREASURER'S FEES AND TAXES	0.00		-88.00		
414.103 · FINANCE OFFICE	0.00	10,666.67	0.00	53,333.31	128,000.00
414.104 · FINANCE DEPT PAYROLL TAXES	0.00	816.00	0.00	4,080.00	9,792.00
414.105 · FINANCE DEPT / INSURANCE	0.00	0.00	0.00	0.00	0.00
414.106 · FINANCE DEPT / RETIREMENT	0.00	0.00	0.00	0.00	0.00
414.110 · FINANCE DEPT / WORKERS COMP	0.00	0.00	0.00	0.00	0.00
414.218 · FINANCE DEPT / POSTAGE	347.26	250.00	1,084.74	1,250.00	3,000.00
414.220 · FINANCE LEGAL FEES AND ADVICE	1,410.16	41.67	1,410.16	208.31	500.00
414.221 · FINANCE DEPT / TRAINING AND ED.	0.00	20.83	0.00	104.19	250.00
414.223 · FINANCE DEPT. PROF. SERVICES					
414.224 · FINANCE DEPT. AUDIT SERVICES	0.00	2,000.00	0.00	10,000.00	24,000.00
414.223 · FINANCE DEPT. PROF. SERVICES - Ot...	4,925.00	3,333.33	23,485.00	16,666.69	40,000.00
Total 414.223 · FINANCE DEPT. PROF. SERVICES	4,925.00	5,333.33	23,485.00	26,666.69	64,000.00
414.230 · FINANCE DEPT CONTRACT SERV	3,296.42	2,583.33	17,274.68	12,916.69	31,000.00
414.237 · FINANCE OTHER FEES & TAXES	0.00		5,073.74		
414.341 · FINANCE DEPT / SUPPLIES	0.00	83.33	103.69	416.69	1,000.00
415.101 · CITY CLERK'S OFFICE - SALARY	8,850.00	3,250.00	47,700.69	16,250.00	39,000.00
415.104 · CITY CLERK'S OFFICE-PAYROLL TAX	666.92	248.67	3,643.14	1,243.31	2,984.00
415.105 · CITY CLERK'S OFFICE-EMP INSURAN	0.00	0.00	0.00	0.00	0.00
415.106 · CITY CLERK'S OFFICE-RETIREMENT	4,160.14	0.00	9,846.54	0.00	0.00
415.110 · CITY CLERK / WORKERS COMP	0.00	0.00	0.00	0.00	0.00
415.218 · CITY CLERK'S POSTAGE	0.00	333.33	0.00	1,666.69	4,000.00
415.220 · CITY CLERK'S ADV/ LEGAL	0.00	83.33	0.00	416.69	1,000.00
415.221 · CITY CLERK'S TRAINING & ED	0.00	83.33	649.72	416.69	1,000.00
415.222 · CITY CLERK'S DUES & SUBSCRIPTIO	0.00	83.33	35.00	416.69	1,000.00
415.341 · CITY CLERKS SUPPLIES & MATERIAL	0.00	83.33	579.08	416.69	1,000.00

CITY OF WESTON
Profit & Loss Budget Performance

November 2021

	Nov 21	Budget	Jul - Nov 21	YTD Budget	Annual Budget
415.343 · CITY MANAGER FUEL	60.23		60.23		
416.101 · POLICE JUDGE'S OFFICAL'S SALARY	0.00	983.33	0.00	4,916.69	11,800.00
416.104 · POLICE JUDGE'S PAYROLL TAX	0.00	75.25	0.00	376.25	903.00
416.221 · POLICE JUDGE'S TRAINING & ED	0.00	41.67	0.00	208.31	500.00
416.341 · POLICE JUDGE SUPPLIES & MATER	0.00	83.33	0.00	416.69	1,000.00
417.103 · CITY ATTORNEY SALARIES & WAGES	2,219.44	2,500.00	10,956.34	12,500.00	30,000.00
417.104 · CITY ATTORNEY PAYROLL TAXES	169.79	191.25	838.15	956.25	2,295.00
417.220 · CITY ATTORNEY LEGAL FEES ADVICE	0.00	83.33	0.00	416.69	1,000.00
417.221 · ATTORNEY TRAINING FEES	0.00	41.67	0.00	208.31	500.00
417.223 · CITY ATTORNEY PROFESSION SERVIC	962.50	1,000.00	8,878.92	5,000.00	12,000.00
417.341 · CITY ATTORNEY / SUPPLIES	0.00	166.67	0.00	833.31	2,000.00
419.240 · MAIN ST / FACADE IMPROVEMENT	0.00	833.33	0.00	4,166.69	10,000.00
419.341 · MAIN ST BEAUTIFICATION SUPPLIES	80.00	250.00	579.62	1,250.00	3,000.00
424.000 · CONTRIBUTIONS TO COMMS/AUTHORIT	0.00	0.00	0.00	0.00	0.00
435.222 · REGIONAL DEV AUTHORITY-DUES&SUB	0.00	416.67	4,727.00	2,083.31	5,000.00
436.101 · CODE ENFORCEMENT WAGES	6,631.29	6,083.33	30,369.83	30,416.69	73,000.00
436.104 · CODE ENFORCEMENT-PAYROLL TAX	500.44	459.00	2,297.22	2,295.00	5,508.00
436.105 · CODE ENFORCEMENT-EMP INSURANC	0.00	0.00	0.00	0.00	0.00
436.106 · CODE ENFORCEMENT-RETIREMENT	0.00	0.00	0.00	0.00	0.00
436.110 · CODE ENFORCEMENT WORKERS COMP	0.00	0.00	0.00	0.00	0.00
436.217 · CODE ENFORMENT VEHICLE MAINT	0.00	83.33	809.66	416.69	1,000.00
436.220 · CODE ENFORCEMENT LEGAL ADS	1,557.76	333.33	2,072.76	1,666.69	4,000.00
436.221 · CODE ENFORCEMENT TRAINING & ED	232.14	83.33	307.14	416.69	1,000.00
436.222 · CODE ENFORCEMENT / DUES & SUB	0.00	166.67	0.00	833.31	2,000.00
436.230 · CODE ENFORCEMENT CONTRACT SVC	480.00	5,708.33	1,202.25	28,541.69	68,500.00
436.341 · CODE ENFORCEMENT SUPPLIES	49.50	416.67	122.88	2,083.31	5,000.00
436.343 · CODE ENFORCEMENT FUEL	58.91	183.33	404.75	916.69	2,200.00
436.345 · CODE ENFORCEMENT / UNIFORMS	0.00	75.00	166.80	375.00	900.00
437.000 · CITY HALL PLANNING AND ZONING	0.00	0.00	0.00	0.00	0.00
440.105 · CITY HALL CONTRIBUTION INSURANC	28,530.71	25,923.08	125,676.06	129,615.44	311,077.00
440.106 · CITY HALL / CPRB CONTRIBUTIONS	0.00	5,016.00	3,856.90	25,080.00	60,192.00
440.109 · CITY HALL EYE AND DENTAL INSUR	4,509.36	83.33	8,968.64	4,166.69	10,000.00
440.112 · CITY HALL WORKERS COMP	3,978.00	3,323.67	56,232.96	16,618.31	39,884.00
440.113 · CITY HALL / EYE & DENTAL INS	0.00	833.33	0.00	4,166.69	10,000.00
440.114 · COMMERCIAL LIABILITY INS	0.00	4,702.25	28,364.42	23,511.25	56,427.00
440.115 · CITY HALL / COLONIAL INS	0.00	900.00	908.84	4,500.00	10,800.00
440.116 · CITY HALL / WVML UNEMPLOYMENT	0.00	1,250.00	988.91	6,250.00	15,000.00
440.211 · CITY HALL TELEPHONE	254.04	391.67	1,117.19	1,958.31	4,700.00
440.213 · CITY HALL UTILITIES					
440.250 · CITY HALL GAS UTILITY	0.00	208.33	156.70	1,041.69	2,500.00
440.251 · CITY HALL WATER	0.00	100.00	202.59	500.00	1,200.00
440.253 · CITY HALL ELECTRIC	0.00	425.00	0.00	2,125.00	5,100.00
440.213 · CITY HALL UTILITIES - Other	399.10	0.00	2,972.31	0.00	0.00
Total 440.213 · CITY HALL UTILITIES	399.10	733.33	3,331.60	3,666.69	8,800.00
440.215 · CITY HALL M & R BLDGS & GROUNDS	0.00	250.00	0.00	1,250.00	3,000.00
440.216 · CITY HALL M & R EQUIPMENT	0.00	416.67	0.00	2,083.31	5,000.00
440.218 · CITY HALL POSTAGE	0.00	750.00	28.20	3,750.00	9,000.00
440.220 · CITY HALL - ADVERTISING	0.00	250.00	114.44	1,250.00	3,000.00
440.221 · CITY HALL TRAINING / TUITION	955.80	83.33	955.80	416.69	1,000.00
440.222 · CITY HALL DUES & SUBS	2,150.00	125.00	2,989.06	625.00	1,500.00
440.223 · CITY HALL-CONTRACTED SERVICES	0.00	83.33	0.00	416.69	1,000.00
440.224 · CITY HALL -LEGAL AND AUDITING	0.00	83.33	0.00	416.69	1,000.00
440.229 · CITY HALL COMPUTER SER & SOFTWA	2,389.28	1,416.67	10,088.42	7,083.31	17,000.00
440.230 · CITY HALL CONTRACTED SERVICES	1,381.77	83.33	4,275.21	416.69	1,000.00
440.232 · CITY HALL BANK CHARGES	503.33	41.67	4,156.28	208.31	500.00
440.236 · CITY H ALL PROPERTY TAXES	0.00	41.67	285.14	208.31	500.00
440.252 · CITY HALL SANITARY SEWAGE	74.34	41.67	184.98	208.31	500.00
440.341 · CITY HALL SUPPLIES & MATERIALS	1,049.98	750.00	4,135.88	3,750.00	9,000.00
440.343 · CITY HALL / GASOLINE AND OIL	0.00	83.33	0.00	416.69	1,000.00
440.345 · CITY HALL / UNIFORMS	0.00	25.00	0.00	125.00	300.00
571.101 · PARKING SALARIES & WAGES	0.00	0.00	0.00	0.00	0.00
698.000 · TRANSFERS / REIMBURSEMENTS	0.00	12,500.00	0.00	62,500.00	150,000.00
700.101 · POLICE OFFICIAL'S SALARIES	0.00	0.00	0.00	0.00	0.00
700.103 · POLICE SALARIES & WAGES	28,240.91	28,399.67	138,673.67	141,998.31	340,796.00
700.104 · POLICE PAYROLL TAXES	1,307.11	2,172.58	6,405.20	10,862.94	26,071.00
700.105 · POLICE EMPLOYEE INSURANCE	0.00	0.00	0.00	0.00	0.00
700.106 · POLICE RETIREMENT CPRB	0.00	1,032.92	0.00	5,164.56	12,395.00
700.107 · POLICE CONTRIBUTION TO PENSION	2,281.90	2,500.00	12,593.87	12,500.00	30,000.00
700.110 · POLICE WORKERS COMP	0.00	0.00	0.00	0.00	0.00
700.211 · POLICE TELEPHONE	0.00	600.00	0.00	3,000.00	7,200.00
700.212 · POLICE DEPARTMEN WIRELESS PHONE	1,172.36		3,518.06		
700.214 · POLICE TRAVEL	0.00	250.00	0.00	1,250.00	3,000.00
700.216 · POLICE M & R EQUIPMENT	722.00	250.00	3,559.99	1,250.00	3,000.00
700.217 · POLICE M & R AUTOS/TRUCKS	385.97	708.33	6,216.88	3,541.69	8,500.00
700.218 · POLICE POSTAGE	0.00		24.80		
700.220 · POLICE - ADVERTISING	75.00		75.00		
700.221 · POLICE TRAINING & EDUCATION	135.00	625.00	344.69	3,125.00	7,500.00
700.222 · POLICE DUES & SUBSCRIPTION	0.00	8.33	0.00	41.69	100.00
700.223 · POLICE PROFESSIONAL SERVICES	4,784.00	166.67	4,910.22	833.31	2,000.00
700.225 · POLICE LAUNDRY & DRY CLEANING	0.00		74.00		
700.229 · POLICE COURT COST & DAMAGES	410.00		1,270.00		
700.230 · POLICE CONTRACTED SERVICES	2,033.00	125.00	2,208.00	625.00	1,500.00
700.232 · POLICE / COMPUTER SOFTWARE	85.00	83.33	176.59	416.69	1,000.00
700.341 · POLICE SUPPLIES & MATERIALS	0.00	520.83	24.17	2,604.19	6,250.00
700.343 · POLICE FUEL, OIL & TIRES	1,199.40	1,500.00	4,292.07	7,500.00	18,000.00
700.345 · POLICE UNIFORMS	0.00	279.17	239.56	1,395.81	3,350.00
700.350 · POLICE - K-9 EXPENSES	0.00		875.00		
700.459 · POLICE CAPITAL OUTLAY	0.00	4,533.33	33,422.72	22,666.69	54,400.00
706 · 106 - FIREMEN RETIREMENT EXPEN	0.00	435.67	0.00	2,178.31	5,228.00
706.103 · FIRE DEPT SALARIES & WAGES	14,309.24	15,168.33	79,939.19	75,841.69	182,020.00
706.104 · FIRE DEPT PAYROLL TAXES	515.24	1,160.42	3,032.25	5,802.06	13,925.00
706.105 · FIRE DEPT EMPLOYEE INSURANCE	0.00	0.00	0.00	0.00	0.00
706.106 · FIRE DEPT RETIREMENT CPRB	0.00	435.67	0.00	2,178.31	5,228.00
706.107 · FIRE DEPT CONTRIBUTION TO PENSI	1,968.90	3,333.33	13,469.55	16,666.69	40,000.00
706.110 · FIRE DEPT WORKERS COMP	0.00	1,250.00	0.00	6,250.00	15,000.00
706.114 · FIRE DEPARTMENT VFD INSURANCE	21,748.68	2,500.00	21,748.68	12,500.00	30,000.00
706.211 · FIRE DEPT TELEPHONE	156.53	285.00	463.28	1,425.00	3,420.00
706.213 · FIRE DEPT UTILITIES ELECTRIC	637.49	333.33	3,754.70	1,666.69	4,000.00
706.215 · FIRE DEPT / BUILDING MAINT.	0.00	666.67	0.00	3,333.31	8,000.00
706.216 · FIRE DEPT EQUIP MAINT	691.25	666.67	14,695.32	3,333.31	8,000.00
706.217 · FD VEHICLE MAINTENANCE	0.00	625.00	56.00	3,125.00	7,500.00

**CITY OF WESTON
Profit & Loss Budget Performance**

November 2021

	Nov 21	Budget	Jul - Nov 21	YTD Budget	Annual Budget
706.221 · FIRE DEPT TRAINING / TUITION	0.00	166.67	0.00	833.31	2,000.00
706.223 · F D PROFESSIONAL SERVICES	800.00	800.00	375.00	1,875.00	4,500.00
706.230 · FIRE DEPT CONTRACTED SERVICES	0.00	83.33	666.00	416.69	1,000.00
706.250 · FIRE DEPT GAS UTILITY	83.39	291.67	398.36	1,458.31	3,500.00
706.251 · FIRE DEPT WATER	34.24	62.50	101.28	312.50	750.00
706.252 · FIRE DEPT SANITARY SEWAGE	31.42	62.50	119.96	312.50	750.00
706.255 · FIRE DEPARTMENT WIRELESS PHONE	137.82		461.33		
706.341 · FD MATERIAL & SUPPLIES	0.00	416.67	0.00	2,083.31	5,000.00
706.343 · FIRE DEPT GAS & OIL	278.61	666.67	1,309.97	3,333.31	8,000.00
706.345 · FIRE DEPT UNIFORMS	0.00	291.67	167.20	1,458.31	3,500.00
706.353 · FIRE DEPT / SOFTWARE	0.00	70.83	0.00	354.19	850.00
706.458 · FD CAPITAL OUTLAY OTHER IMP	0.00	1,666.67	0.00	8,333.31	20,000.00
706.459 · FD CAPITAL OUTLAY AUTO/EQUIP	0.00	8,247.58	0.00	41,237.94	98,971.00
711.230 · COMM. CENTER 911 CONTRACTED SER	3,300.00	3,300.00	13,200.00	16,500.00	39,600.00
714.001 · POLK CREEK WATER SHED AGREEMENT	0.00	375.00	0.00	1,875.00	4,500.00
715.213 · FIRE HYDRANTS - UTILITIES	0.00	500.00	0.00	2,500.00	6,000.00
715.251 · FIRE HYDRANT WATER UTILITY	580.02		2,619.74		
750.101 · STREETS & HWY OFFICAL'S SALARIE	0.00	0.00	0.00	0.00	0.00
750.103 · STREETS & HWY SALARIES & WAGES	16,304.10	18,701.50	92,747.48	93,507.50	224,418.00
750.104 · STREETS & HWY PAYROLL TAX	1,209.41	1,430.67	6,887.21	7,153.31	17,168.00
750.105 · STREETS & HWY EMPL INSURANCE	0.00	5,424.08	0.00	27,120.44	65,089.00
750.106 · STREETS & HWY RETIREMENT EXPENS	0.00	1,620.17	0.00	8,100.81	19,442.00
750.110 · STREETS & HWY WORKERS COMP	0.00	240.00	0.00	1,200.00	2,880.00
750.211 · STREETS & HWY TELEPHONE	0.00	208.33	0.00	1,041.69	2,500.00
750.213 · STREETS & HWY UTILITIES					
750.250 · STREET DEPT GAS UTILITY	0.00	541.67	143.65	2,708.31	6,500.00
750.253 · STREET DEPT / ELECTRIC	0.00	416.67	0.00	2,083.31	5,000.00
750.213 · STREETS & HWY UTILITIES - Other	405.46		1,572.15		
Total 750.213 · STREETS & HWY UTILITIES	405.46	958.34	1,715.80	4,791.62	11,500.00
750.215 · STREETS & HWY BLDG & GROUNDS	253.34	187.50	253.34	937.50	2,250.00
750.216 · STREETS & HWY M & R EQUIPMENT	699.81	416.67	4,384.29	2,083.31	5,000.00
750.217 · STREETS & HWY M & R AUTOS & TRU	166.03	416.67	1,885.86	2,083.31	5,000.00
750.219 · STREETS & HWY BLDG & EQUIP RENT	0.00	416.67	636.62	2,083.31	5,000.00
750.220 · STREETS & HWY ADV/LEGAL	0.00	20.83	0.00	104.19	250.00
750.221 · STREETS & HWY TRAINING & ED	0.00	83.33	0.00	416.69	1,000.00
750.222 · STREETS & HWY DUES & SUBS	0.00	41.67	0.00	208.31	500.00
750.223 · STREETS & HWY PROFESSIONAL FEES	774.04	833.33	6,094.82	4,166.69	10,000.00
750.230 · STREETS & HWY CONTRACTED SERVIC	405.00	541.67	405.00	2,708.31	6,500.00
750.251 · STREET DEPT WATER	0.00	266.67	235.63	1,333.31	3,200.00
750.252 · STREET DEPT SANITARY SEWAGE	68.58	208.33	300.74	1,041.69	2,500.00
750.341 · STREETS & HWY SUPPLIES & MAT					
750.600 · STREET DEPT HOT MIX ASPHALT			166.42		
750.602 · SEWER CUTS AND REPAIR	0.00				
750.600 · STREET DEPT HOT MIX ASPHALT - ...	696.21	833.33	6,922.85	4,166.69	10,000.00
Total 750.600 · STREET DEPT HOT MIX ASPHALT	696.21	833.33	7,089.27	4,166.69	10,000.00
750.601 · STREET DEPT STONE	0.00	416.67	0.00	2,083.31	5,000.00
750.620 · STREET DEPT STREET SIGNS	40.58		2,409.06		
750.341 · STREETS & HWY SUPPLIES & MAT - O...	2,014.17	0.00	6,671.06	0.00	0.00
Total 750.341 · STREETS & HWY SUPPLIES & MAT	2,750.96	1,250.00	16,169.39	6,250.00	15,000.00
750.342 · STORMWATER DRAIN REPAIR/REPLACE	2,646.11		3,644.43		
750.343 · STREETS & HWY FUEL, OIL & TIRES	1,164.93	833.33	3,785.90	4,166.69	10,000.00
750.345 · STREET DEPT UNIFORMS	661.82	233.33	1,578.26	1,166.69	2,800.00
750.457 · CAPITAL OUTLAY-BUILDINGS	0.00	1,250.00	0.00	6,250.00	15,000.00
750.459 · STREETS & HWY CAPITAL OUTLAY	0.00	10,416.67	0.00	52,083.31	125,000.00
750.615 · STREET DEPT DISPOSAL	0.00	83.33	376.85	416.69	1,000.00
751.213 · STREET LIGHTS UTILITIES	4,862.10	4,750.00	23,874.94	23,750.00	57,000.00
752.213 · SIGNS & SIGNALS UTILITIES	175.94	200.00	898.17	1,000.00	2,400.00
752.341 · SIGNS & SIGNALS SUPPLIES & MAT	0.00	500.00	0.00	2,500.00	6,000.00
752.459 · SIGNS & SIGNALS / EQUIP CAPITAL	0.00	416.67	0.00	2,083.31	5,000.00
753.000 · STREETS SNOW REMOVAL	0.00	0.00	0.00	0.00	0.00
753.230 · SNOW REMOVAL CONTRACT SVCS	0.00	208.33	0.00	1,041.69	2,500.00
753.341 · SNOW REMOVAL SUPPLIES	0.00	625.00	0.00	3,125.00	7,500.00
753.459 · SNOW REMOVAL / EQUIP CAPITAL	0.00	408.33	4,900.00	2,041.69	4,900.00
755.230 · Street Const-Contracted Svcs	0.00	15,000.00	0.00	75,000.00	180,000.00
755.341 · STREET CONST. SUPPLIES	0.00	833.33	0.00	4,166.69	10,000.00
756.230 · ST. CLEANING CONTRACT SVCS	0.00	208.33	0.00	1,041.69	2,500.00
756.341 · ST. CLEANING SUPPLIES	0.00	1,250.00	0.00	6,250.00	15,000.00
756.459 · ST. CLEANING EQUIP. CAPITAL	0.00	0.00	0.00	0.00	0.00
757.341 · SIDEWALKS / SUPPLIES	0.00	0.00	0.00	0.00	0.00
805.341 · STORM SEWER / SUPPLIES	0.00	1,875.00	0.00	9,375.00	22,500.00
805.459 · STORM SEWER / EQUIP. CAPITAL	0.00	0.00	0.00	0.00	0.00
900.000 · Parks and Recreation	0.00	958.33	0.00	4,791.69	11,500.00
900.230 · RECREATION CONTRACTED SERVICES	3,740.00		4,011.30		
900.341 · RECREATION SUPPLIES	1,271.37		1,391.67		
903.000 · NON GRANT EXPENSES FROM DONATIO FAIRS AND FESTIVALS	0.00	0.00	0.00	0.00	0.00
Total 903.000 · NON GRANT EXPENSES FROM DO...	0.00	0.00	0.00	0.00	0.00
914.000 · Rails to Trails	0.00	0.00	0.00	0.00	0.00
920.002 · WV CULTURE & HISTORY GRANT	0.00	0.00	0.00	0.00	0.00
950.230 · BEAUTIFICATION-CONTRACTED SVCS	0.00	0.00	900.00	0.00	0.00
950.341 · BEAUTIFICATION-SUPPLIES	80.56		80.56		
952.103 · CEMETARY / SALARIES	0.00	200.00	0.00	1,000.00	2,400.00
952.104 · CEMETARY / PAYROLL TAXES	0.00	15.33	0.00	76.69	184.00
952.230 · CEMETERIES CONTRACTED SERVICES	1,100.00	1,283.33	4,900.00	6,416.69	15,400.00
952.341 · Cemetary materials & supplies	658.80		1,143.28		
975.000 · GENERAL GOV. / CAPITAL IMPROV	0.00	11,661.42	0.00	58,307.06	139,937.00
976.000 · PUBLIC SAFETY / CAPITAL IMPROV	0.00	0.00	0.00	0.00	0.00
977.000 · STREET DEPT-S/T CAP IMPROVEMENT	0.00	10,000.00	360.00	50,000.00	120,000.00
977.700 · CROSSROADS	0.00		300.00		
978.000 · HEALTH & SAN. / CAPITAL IMPROV	0.00	0.00	0.00	0.00	0.00
979.000 · CULTURE & REC / CAPITAL IMPROV	0.00	6,250.00	0.00	31,250.00	75,000.00
980.000 · SOCIAL SVCS / CAPITAL IMPROV	0.00	0.00	0.00	0.00	0.00
Total Expense	215,220.40	301,716.65	1,018,278.09	1,508,583.45	3,620,600.00
Net Ordinary Income	-61,932.89	-107,265.96	1,226,556.64	-536,330.28	-1,287,192.00
Other Income/Expense					
Other Income					

10:12 AM

12/06/21

Cash Basis

CITY OF WESTON
Profit & Loss Budget Performance

November 2021

	<u>Nov 21</u>	<u>Budget</u>	<u>Jul - Nov 21</u>	<u>YTD Budget</u>	<u>Annual Budget</u>
Management Review	1,272.16		10,272.16		
Total Other Income	1,272.16		10,272.16		
Net Other Income	1,272.16	0.00	10,272.16	0.00	0.00
Net Income	<u>-60,660.73</u>	<u>-107,265.96</u>	<u>1,236,828.80</u>	<u>-536,330.28</u>	<u>-1,287,192.00</u>

CITY OF WESTON
Profit & Loss Budget vs. Actual
November 2021

	Nov 21	Budget	\$ Over Budget	% of Budget
Ordinary Income/Expense				
Income				
wv coal severance	0.00	0.00	0.00	0.0%
301.000 · PROPERTY (AD VALOREM) TAXES	10,845.82	33,256.17	-22,410.35	32.6%
302.000 · TAX PENALTIES & INTEREST	973.77	416.67	557.10	233.7%
303.000 · GAS & OIL SERVANCE TAX	0.00	479.17	-479.17	0.0%
304.000 · EXCISE TAX ON UTILITIES	65,496.15	26,666.67	38,829.48	245.6%
305.000 · B & O TAX	44,016.38	37,500.00	6,516.38	117.4%
306.000 · WINE & LIQUOR TAX (WLP)	0.00	4,916.67	-4,916.67	0.0%
307.000 · ANIMAL CONTROL TAX	70.20	83.33	-13.13	84.2%
314.000 · Sales Tax Revenue	0.00	47,916.67	-47,916.67	0.0%
320.000 · FINES, FEES & COURT COSTS	268.00	416.67	-148.67	64.3%
321.000 · PARKING VIOLATIONS	0.00	41.67	-41.67	0.0%
325.000 · LICENSES	780.00	875.00	-95.00	89.1%
326.000 · PERMIT FEES	3,190.00	0.00	3,190.00	100.0%
328.000 · FRANCHISE FEES	3,058.20	3,125.00	-66.80	97.9%
330.000 · IRP FEES	5,338.97	2,916.67	2,422.30	183.1%
336.000 · CEMETERY REVENUES	0.00	83.33	-83.33	0.0%
341.000 · MUNICIPAL SERVICE FEES	12,216.79	23,500.00	-11,283.21	52.0%
342.000 · PARKING METER REVENUES	0.00	83.33	-83.33	0.0%
343.000 · OFF STREET PARKING	240.00	250.00	-10.00	96.0%
344.000 · COLLECTIONS DELINQUENT ACCTS	0.00	0.00	0.00	0.0%
352.000 · FIRE PROTECTION FEE	0.00	833.33	-833.33	0.0%
361.000 · CHARGES FOR SERVICES	0.00	0.00	0.00	0.0%
367.000 · Other Grants	0.00	0.00	0.00	0.0%
376.000 · VIDEO LOTTERY/GAMBLING INCOME				
376.001 · GREENBRIER DISTRIBUTION INCOME	31.03			
376.002 · TABLE GAMES DISTRIBUTION INCOME	936.20			
376.000 · VIDEO LOTTERY/GAMBLING INCOME - Other	0.00	625.00	-625.00	0.0%
Total 376.000 · VIDEO LOTTERY/GAMBLING INCOME	967.23	625.00	342.23	154.8%
381.000 · REIMBURSEMENTS	3,488.82	8,507.00	-5,018.18	41.0%
382.00 · Refunds and Rebates	0.00	125.00	-125.00	0.0%
383.000 · SALE OF FIXED ASSETS	0.00	0.00	0.00	0.0%
389.000 · ACCIDENT REPORTS/INCIDENT	420.00	166.67	253.33	252.0%
397.000 · Video Lottery (LVL)	1,877.18	1,666.67	210.51	112.6%
399.000 · MISCELLANEOUS REVENUE	40.00	0.00	40.00	100.0%
Total Income	153,287.51	194,450.69	-41,163.18	78.8%
Gross Profit	153,287.51	194,450.69	-41,163.18	78.8%
Expense				
103.0 · Salaries	0.00			
104.0 · Payroll Taxes	0.00			
409.103 · MAYOR'S OFFICE OFFICIALS SALARIE	0.00	500.00	-500.00	0.0%
409.104 · MAYOR'S OFFICE PAYROLL TAXES	0.00	38.25	-38.25	0.0%
410.103 · CITY COUNCIL OFFICIAL'S SALARIES	1,300.00	800.00	500.00	162.5%
410.104 · CITY COUNCIL PAYROLL TAXES	99.45	61.17	38.28	162.6%
410.341 · CITY COUNCIL MATERIALS & SUPPLY	0.00	41.67	-41.67	0.0%
412.103 · CITY MANAGER WAGES	2,932.80	5,416.67	-2,483.87	54.1%
412.104 · CITY MANAGER-PAYROLL TAXES	215.12	414.42	-199.30	51.9%
412.105 · CITY MANAGER'S EMP INSURANCE	0.00	0.00	0.00	0.0%
412.106 · CITY MANAGER RETIREMENT EXPENSE	0.00	0.00	0.00	0.0%
412.110 · CITY MANAGER'S WORKERS COMP	0.00	0.00	0.00	0.0%
412.211 · CITY MANAGER TELEPHONE	201.58			
412.220 · CITY MANAGER ADV. / LEGAL	0.00	41.67	-41.67	0.0%
412.221 · CITY MANAGER TRAINING AND ED	135.00	41.67	93.33	324.0%
412.222 · CITY MANAGER DUES / SUBSCRIP	0.00	41.67	-41.67	0.0%
412.341 · CITY MANAGER'S SUPPLIES & MATER	0.00	83.33	-83.33	0.0%
414.103 · FINANCE OFFICE	0.00	10,666.67	-10,666.67	0.0%
414.104 · FINANCE DEPT PAYROLL TAXES	0.00	816.00	-816.00	0.0%
414.105 · FINANCE DEPT / INSURANCE	0.00	0.00	0.00	0.0%
414.106 · FINANCE DEPT / RETIREMENT	0.00	0.00	0.00	0.0%
414.110 · FINANCE DEPT / WORKERS COMP	0.00	0.00	0.00	0.0%
414.218 · FINANCE DEPT / POSTAGE	347.26	250.00	97.26	138.9%
414.220 · FINANCE LEGAL FEES AND ADVICE	1,410.16	41.67	1,368.49	3,384.1%
414.221 · FINANCE DEPT / TRAINING AND ED.	0.00	20.83	-20.83	0.0%
414.223 · FINANCE DEPT. PROF. SERVICES				
414.224 · FINANCE DEPT. AUDIT SERVICES	0.00	2,000.00	-2,000.00	0.0%
414.223 · FINANCE DEPT. PROF. SERVICES - Other	4,925.00	3,333.33	1,591.67	147.8%

CITY OF WESTON
Profit & Loss Budget vs. Actual
November 2021

	Nov 21	Budget	\$ Over Budget	% of Budget
Total 414.223 · FINANCE DEPT. PROF. SERVICES	4,925.00	5,333.33	-408.33	92.3%
414.230 · FINANCE DEPT CONTRACT SERV	3,296.42	2,583.33	713.09	127.6%
414.341 · FINANCE DEPT / SUPPLIES	0.00	83.33	-83.33	0.0%
415.101 · CITY CLERK'S OFFICE - SALARY	8,850.00	3,250.00	5,600.00	272.3%
415.104 · CITY CLERK'S OFFICE-PAYROLL TAX	666.92	248.67	418.25	268.2%
415.105 · CITY CLERK'S OFFICE-EMP INSURAN	0.00	0.00	0.00	0.0%
415.106 · CITY CLERK'S OFFICE-RETIREMENT	4,160.14	0.00	4,160.14	100.0%
415.110 · CITY CLERK / WORKERS COMP	0.00	0.00	0.00	0.0%
415.218 · CITY CLERK'S POSTAGE	0.00	333.33	-333.33	0.0%
415.220 · CITY CLERK'S ADV/ LEGAL	0.00	83.33	-83.33	0.0%
415.221 · CITY CLERK'S TRAINING & ED	0.00	83.33	-83.33	0.0%
415.222 · CITY CLERK'S DUES & SUBSCRIPTIO	0.00	83.33	-83.33	0.0%
415.341 · CITY CLERKS SUPPLIES & MATERIAL	0.00	83.33	-83.33	0.0%
415.343 · CITY MANAGER FUEL	60.23			
416.101 · POLICE JUDGE'S OFFICAL'S SALARY	0.00	983.33	-983.33	0.0%
416.104 · POLICE JUDGE'S PAYROLL TAX	0.00	75.25	-75.25	0.0%
416.221 · POLICE JUDGE'S TRAINING & ED	0.00	41.67	-41.67	0.0%
416.341 · POLICE JUDGE SUPPLIES & MATER	0.00	83.33	-83.33	0.0%
417.103 · CITY ATTORNEY SALARIES & WAGES	2,219.44	2,500.00	-280.56	88.8%
417.104 · CITY ATTORNEY PAYROLL TAXES	169.79	191.25	-21.46	88.8%
417.220 · CITY ATTORNEY LEGAL FEES ADVICE	0.00	83.33	-83.33	0.0%
417.221 · ATTORNEY TRAINING FEES	0.00	41.67	-41.67	0.0%
417.223 · CITY ATTORNEY PROFESSION SERVIC	962.50	1,000.00	-37.50	96.3%
417.341 · CITY ATTORNEY / SUPPLIES	0.00	166.67	-166.67	0.0%
419.240 · MAIN ST / FACADE IMPROVEMENT	0.00	833.33	-833.33	0.0%
419.341 · MAIN ST BEAUTIFICATION SUPPLIES	80.00	250.00	-170.00	32.0%
424.000 · CONTRIBUTIONS TO COMMS/AUTHORIT	0.00	0.00	0.00	0.0%
435.222 · REGIONAL DEV AUTHORITY-DUES&SUB	0.00	416.67	-416.67	0.0%
436.101 · CODE ENFORCEMENT WAGES	6,631.29	6,083.33	547.96	109.0%
436.104 · CODE ENFORCEMENT-PAYROLL TAX	500.44	459.00	41.44	109.0%
436.105 · CODE ENFORCEMENT-EMP INSURANC	0.00	0.00	0.00	0.0%
436.106 · CODE ENFORCEMENT-RETIREMENT	0.00	0.00	0.00	0.0%
436.110 · CODE ENFORCEMENT WORKERS COMP	0.00	0.00	0.00	0.0%
436.217 · CODE ENFORMENT VEHICLE MAINT	0.00	83.33	-83.33	0.0%
436.220 · CODE ENFORCEMENT LEGAL ADS	1,557.76	333.33	1,224.43	467.3%
436.221 · CODE ENFORCEMENT TRAINING & ED	232.14	83.33	148.81	278.6%
436.222 · CODE ENFORCEMENT / DUES & SUB	0.00	166.67	-166.67	0.0%
436.230 · CODE ENFORCEMEMENT CONTRACT SVC	480.00	5,708.33	-5,228.33	8.4%
436.341 · CODE ENFORCEMENT SUPPLIES	49.50	416.67	-367.17	11.9%
436.343 · CODE ENFORCEMENT FUEL	58.91	183.33	-124.42	32.1%
436.345 · CODE ENFORCEMENT / UNIFORMS	0.00	75.00	-75.00	0.0%
437.000 · CITY HALL PLANNING AND ZONING	0.00	0.00	0.00	0.0%
440.105 · CITY HALL CONTRIBUTION INSURANC	28,530.71	25,923.08	2,607.63	110.1%
440.106 · CITY HALL / CPRB CONTRIBUTIONS	0.00	5,016.00	-5,016.00	0.0%
440.109 · CITY HALL EYE AND DENTAL INSUR	4,509.36			
440.112 · CITY HALL WORKERS COMP	3,978.00	3,323.67	654.33	119.7%
440.113 · CITY HALL / EYE & DENTAL INS	0.00	833.33	-833.33	0.0%
440.114 · COMMERCIAL LIABILITY INS	0.00	4,702.25	-4,702.25	0.0%
440.115 · CITY HALL / COLONIAL INS	0.00	900.00	-900.00	0.0%
440.116 · CITY HALL / WVML UNEMPLOYMENT	0.00	1,250.00	-1,250.00	0.0%
440.211 · CITY HALL TELEPHONE	254.04	391.67	-137.63	64.9%
440.213 · CITY HALL UTILITIES				
440.250 · CITY HALL GAS UTILITY	0.00	208.33	-208.33	0.0%
440.251 · CITY HALL WATER	0.00	100.00	-100.00	0.0%
440.253 · CITY HALL ELECTRIC	0.00	425.00	-425.00	0.0%
440.213 · CITY HALL UTILITIES - Other	399.10	0.00	399.10	100.0%
Total 440.213 · CITY HALL UTILITIES	399.10	733.33	-334.23	54.4%
440.215 · CITY HALL M & R BLDGS & GROUNDS	0.00	250.00	-250.00	0.0%
440.216 · CITY HALL M & R EQUIPMENT	0.00	416.67	-416.67	0.0%
440.218 · CITY HALL POSTAGE	0.00	750.00	-750.00	0.0%
440.220 · CITY HALL - ADVERTISING	0.00	250.00	-250.00	0.0%
440.221 · CITY HALL TRAINING / TUITION	955.80	83.33	872.47	1,147.0%
440.222 · CITY HALL DUES & SUBS	2,150.00	125.00	2,025.00	1,720.0%
440.223 · CITY HALL-CONTRACTED SERVICES	0.00	83.33	-83.33	0.0%
440.224 · CITY HALL -LEGAL AND AUDITING	0.00	83.33	-83.33	0.0%
440.229 · CITY HALL COMPUTER SER & SOFWA	2,389.28	1,416.67	972.61	168.7%
440.230 · CITY HALL CONTRACTED SERVICES	1,381.77	83.33	1,298.44	1,658.2%
440.232 · CITY HALL BANK CHARGES	503.33	41.67	461.66	1,207.9%
440.236 · CITY H ALL PROPERTY TAXES	0.00	41.67	-41.67	0.0%
440.252 · CITY HALL SANITARY SEWAGE	74.34	41.67	32.67	178.4%
440.341 · CITY HALL SUPPLIES & MATERIALS	1,049.98	750.00	299.98	140.0%
440.343 · CITY HALL / GASOLINE AND OIL	0.00	83.33	-83.33	0.0%

CITY OF WESTON
Profit & Loss Budget vs. Actual
November 2021

	Nov 21	Budget	\$ Over Budget	% of Budget
440.345 · CITY HALL / UNIFORMS	0.00	25.00	-25.00	0.0%
571.101 · PARKING SALARIES & WAGES	0.00	0.00	0.00	0.0%
698.000 · TRANSFERS / REIMBURSEMENTS	0.00	12,500.00	-12,500.00	0.0%
700.101 · POLICE OFFICIAL'S SALARIES	0.00	0.00	0.00	0.0%
700.103 · POLICE SALARIES & WAGES	28,240.91	28,399.67	-158.76	99.4%
700.104 · POLICE PAYROLL TAXES	1,307.11	2,172.58	-865.47	60.2%
700.105 · POLICE EMPLOYEE INSURANCE	0.00	0.00	0.00	0.0%
700.106 · POLICE RETIREMENT CPRB	0.00	1,032.92	-1,032.92	0.0%
700.107 · POLICE CONTRIBUTION TO PENSION	2,281.90	2,500.00	-218.10	91.3%
700.110 · POLICE WORKERS COMP	0.00	0.00	0.00	0.0%
700.211 · POLICE TELEPHONE	0.00	600.00	-600.00	0.0%
700.212 · POLICE DEPARTMENT WIRELESS PHONE	1,172.36			
700.214 · POLICE TRAVEL	0.00	250.00	-250.00	0.0%
700.216 · POLICE M & R EQUIPMENT	722.00	250.00	472.00	288.8%
700.217 · POLICE M & R AUTOS/TRUCKS	385.97	708.33	-322.36	54.5%
700.220 · POLICE - ADVERTISING	75.00			
700.221 · POLICE TRAINING & EDUCATION	135.00	625.00	-490.00	21.6%
700.222 · POLICE DUES & SUBSCRIPTION	0.00	8.33	-8.33	0.0%
700.223 · POLICE PROFESSIONAL SERVICES	4,784.00	166.67	4,617.33	2,870.3%
700.229 · POLICE COURT COST & DAMAGES	410.00			
700.230 · POLICE CONTRACTED SERVICES	2,033.00	125.00	1,908.00	1,626.4%
700.323 · POLICE / COMPUTER SOFTWARE	85.00	83.33	1.67	102.0%
700.341 · POLICE SUPPLIES & MATERIALS	0.00	520.83	-520.83	0.0%
700.343 · POLICE FUEL, OIL & TIRES	1,199.40	1,500.00	-300.60	80.0%
700.345 · POLICE UNIFORMS	0.00	279.17	-279.17	0.0%
700.459 · POLICE CAPITAL OUTLAY	0.00	4,533.33	-4,533.33	0.0%
706 · .106 - FIREMEN RETIREMENT EXPEN	0.00	435.67	-435.67	0.0%
706.103 · FIRE DEPT SALARIES & WAGES	14,309.24	15,168.33	-859.09	94.3%
706.104 · FIRE DEPT PAYROLL TAXES	515.24	1,160.42	-645.18	44.4%
706.105 · FIRE DEPT EMPLOYEE INSURANCE	0.00	0.00	0.00	0.0%
706.106 · FIRE DEPT RETIREMENT CPRB	0.00	435.67	-435.67	0.0%
706.107 · FIRE DEPT CONTRIBUTION TO PENS	1,968.90	3,333.33	-1,364.43	59.1%
706.110 · FIRE DEPT WORKERS COMP	0.00	1,250.00	-1,250.00	0.0%
706.114 · FIRE DEPARTMENT VFD INSURANCE	21,748.68	2,500.00	19,248.68	869.9%
706.211 · FIRE DEPT TELEPHONE	156.53	285.00	-128.47	54.9%
706.213 · FIRE DEPT UTILITIES ELECTRIC	637.49	333.33	304.16	191.2%
706.215 · FIRE DEPT / BUILDING MAINT.	0.00	666.67	-666.67	0.0%
706.216 · FIRE DEPT EQUIP MAINT	691.25	666.67	24.58	103.7%
706.217 · FD VEHICLE MAINTENANCE	0.00	625.00	-625.00	0.0%
706.221 · FIRE DEPT TRAINING / TUITION	0.00	166.67	-166.67	0.0%
706.223 · F D PROFESSIONAL SERVICES	800.00	375.00	425.00	213.3%
706.230 · FIRE DEPT CONTRACTED SERVICES	0.00	83.33	-83.33	0.0%
706.250 · FIRE DEPT GAS UTILITY	83.39	291.67	-208.28	28.6%
706.251 · FIRE DEPT WATER	34.24	62.50	-28.26	54.8%
706.252 · FIRE DEPT SANITARY SEWAGE	31.42	62.50	-31.08	50.3%
706.255 · FIRE DEPARTMENT WIRELESS PHONE	137.82			
706.341 · FD MATERIAL & SUPPLIES	0.00	416.67	-416.67	0.0%
706.343 · FIRE DEPT GAS & OIL	278.61	666.67	-388.06	41.8%
706.345 · FIRE DEPT UNIFORMS	0.00	291.67	-291.67	0.0%
706.353 · FIRE DEPT / SOFTWARE	0.00	70.83	-70.83	0.0%
706.458 · FD CAPITAL OUTLAY OTHER IMP	0.00	1,666.67	-1,666.67	0.0%
706.459 · FD CAPITAL OUTLAY AUTO/EQUIP	0.00	8,247.58	-8,247.58	0.0%
711.230 · COMM. CENTER 911 CONTRACTED SER	3,300.00	3,300.00	0.00	100.0%
714.001 · POLK CREEK WATER SHED AGREEMENT	0.00	375.00	-375.00	0.0%
715.213 · FIRE HYDRANTS - UTILITIES	0.00	500.00	-500.00	0.0%
715.251 · FIRE HYDRANT WATER UTILITY	580.02			
750.101 · STREETS & HWY OFFICIAL'S SALARIE	0.00	0.00	0.00	0.0%
750.103 · STREETS & HWY SALARIES & WAGES	16,304.10	18,701.50	-2,397.40	87.2%
750.104 · STREETS & HWY PAYROLL TAX	1,209.41	1,430.67	-221.26	84.5%
750.105 · STREETS & HWY EMPL INSURANCE	0.00	5,424.08	-5,424.08	0.0%
750.106 · STREETS & HWY RETIREMENT EXPENS	0.00	1,620.17	-1,620.17	0.0%
750.110 · STREETS & HWY WORKERS COMP	0.00	240.00	-240.00	0.0%
750.211 · STREETS & HWY TELEPHONE	0.00	208.33	-208.33	0.0%
750.213 · STREETS & HWY UTILITIES				
750.250 · STREET DEPT GAS UTILITY	0.00	541.67	-541.67	0.0%
750.253 · STREET DEPT / ELECTRIC	0.00	416.67	-416.67	0.0%
750.213 · STREETS & HWY UTILITIES - Other	405.46			
Total 750.213 · STREETS & HWY UTILITIES	405.46	958.34	-552.88	42.3%
750.215 · STREETS & HWY BLDG & GROUNDS	253.34	187.50	65.84	135.1%
750.216 · STREETS & HWY M & R EQUIPMENT	699.81	416.67	283.14	168.0%
750.217 · STREETS & HWY M & R AUTOS & TRU	166.03	416.67	-250.64	39.8%

CITY OF WESTON
Profit & Loss Budget vs. Actual
November 2021

	Nov 21	Budget	\$ Over Budget	% of Budget
750.219 · STREETS & HWY BLDG & EQUIP RENT	0.00	416.67	-416.67	0.0%
750.220 · STREETS & HWY ADV/LEGAL	0.00	20.83	-20.83	0.0%
750.221 · STREETS & HWY TRAINING & ED	0.00	83.33	-83.33	0.0%
750.222 · STREETS & HWY DUES & SUBS	0.00	41.67	-41.67	0.0%
750.223 · STREETS & HWY PROFESSIONAL FEES	774.04	833.33	-59.29	92.9%
750.230 · STREETS & HWY CONTRACTED SERVIC	405.00	541.67	-136.67	74.8%
750.251 · STREET DEPT WATER	0.00	266.67	-266.67	0.0%
750.252 · STREET DEPT SANITARY SEWAGE	68.58	208.33	-139.75	32.9%
750.341 · STREETS & HWY SUPPLIES & MAT				
750.600 · STREET DEPT HOT MIX ASPHALT	696.21	833.33	-137.12	83.5%
750.601 · STREET DEPT STONE	0.00	416.67	-416.67	0.0%
750.620 · STREET DEPT STREET SIGNS	40.58			
750.341 · STREETS & HWY SUPPLIES & MAT - Other	2,014.17	0.00	2,014.17	100.0%
Total 750.341 · STREETS & HWY SUPPLIES & MAT	2,750.96	1,250.00	1,500.96	220.1%
750.342 · STORMWATER DRAIN REPAIR/REPLACE	2,646.11			
750.343 · STREETS & HWY FUEL, OIL & TIRES	1,164.93	833.33	331.60	139.8%
750.345 · STREET DEPT UNIFORMS	661.82	233.33	428.49	283.6%
750.457 · CAPITAL OUTLAY-BUILDINGS	0.00	1,250.00	-1,250.00	0.0%
750.459 · STREETS & HWY CAPITAL OUTLAY	0.00	10,416.67	-10,416.67	0.0%
750.615 · STREET DEPT DISPOSAL	0.00	83.33	-83.33	0.0%
751.213 · STREET LIGHTS UTILITIES	4,862.10	4,750.00	112.10	102.4%
752.213 · SIGNS & SIGNALS UTILITIES	175.94	200.00	-24.06	88.0%
752.341 · SIGNS & SIGNALS SUPPLIES & MAT	0.00	500.00	-500.00	0.0%
752.459 · SIGNS & SIGNALS / EQUIP CAPITAL	0.00	416.67	-416.67	0.0%
753.000 · STREETS SNOW REMOVAL	0.00	0.00	0.00	0.0%
753.230 · SNOW REMOVAL CONTRACT SVCS	0.00	208.33	-208.33	0.0%
753.341 · SNOW REMOVAL SUPPLIES	0.00	625.00	-625.00	0.0%
753.459 · SNOW REMOVAL / EQUIP CAPITAL	0.00	408.33	-408.33	0.0%
755.230 · Street Const-Contracted Svcs	0.00	15,000.00	-15,000.00	0.0%
755.341 · STREET CONST. SUPPLIES	0.00	833.33	-833.33	0.0%
756.230 · ST. CLEANING CONTRACT SVCS	0.00	208.33	-208.33	0.0%
756.341 · ST. CLEANING SUPPLIES	0.00	1,250.00	-1,250.00	0.0%
756.459 · ST. CLEANING EQUIP. CAPITAL	0.00	0.00	0.00	0.0%
757.341 · SIDEWALKS / SUPPLIES	0.00	0.00	0.00	0.0%
805.341 · STORM SEWER / SUPPLIES	0.00	1,875.00	-1,875.00	0.0%
805.459 · STORM SEWER / EQUIP. CAPITAL	0.00	0.00	0.00	0.0%
900.000 · Parks and Recreation	0.00	958.33	-958.33	0.0%
900.230 · RECREATION CONTRACTED SERVICES	3,740.00			
900.341 · RECREATION SUPPLIES	1,271.37			
903.000 · NON GRANT EXPENSES FROM DONATIO FAIRS AND FESTIVALS	0.00	0.00	0.00	0.0%
Total 903.000 · NON GRANT EXPENSES FROM DONATIO	0.00	0.00	0.00	0.0%
914.000 · Rails to Trails	0.00	0.00	0.00	0.0%
920.002 · WV CULTURE & HISTORY GRANT	0.00	0.00	0.00	0.0%
950.230 · BEAUTIFICATION-CONTRACTED SVCS	0.00	0.00	0.00	0.0%
950.341 · BEAUTIFICATION-SUPPLIES	80.56			
952.103 · CEMETARY / SALARIES	0.00	200.00	-200.00	0.0%
952.104 · CEMETARY / PAYROLL TAXES	0.00	15.33	-15.33	0.0%
952.230 · CEMETERIES CONTRACTED SERVICES	1,100.00	1,283.33	-183.33	85.7%
952.341 · Cemetary materials & supplies	658.80			
975.000 · GENERAL GOV. / CAPITAL IMPROV	0.00	11,661.42	-11,661.42	0.0%
976.000 · PUBLIC SAFETY / CAPITAL IMPROV	0.00	0.00	0.00	0.0%
977.000 · STREET DEPT-S/T CAP IMPROVEMENT	0.00	10,000.00	-10,000.00	0.0%
978.000 · HEALTH & SAN. / CAPITAL IMPROV	0.00	0.00	0.00	0.0%
979.000 · CULTURE & REC / CAPITAL IMPROV	0.00	6,250.00	-6,250.00	0.0%
980.000 · SOCIAL SVCS / CAPITAL IMPROV	0.00	0.00	0.00	0.0%
Total Expense	215,220.40	301,716.65	-86,496.25	71.3%
Net Ordinary Income	-61,932.89	-107,265.96	45,333.07	57.7%
Other Income/Expense				
Other Income				
Management Review	1,272.16			
Total Other Income	1,272.16			
Net Other Income	1,272.16	0.00	1,272.16	100.0%
Net Income	-60,660.73	-107,265.96	46,605.23	56.6%

CITY OF WESTON
Balance Sheet
 As of November 30, 2021

	Nov 30, 21
ASSETS	
Current Assets	
Checking/Savings	
101.1 · GENERAL FUNDS 01521008454	1,496,996.02
101.2 · PAYROLL ACCOUNT 01521008506	-40,450.09
101.3 · RAINY DAY FUND 01521224364	995.16
101.4 · POLICE EQUIPMENT 01521101076	495.88
101.75 · POLICE K-9 FUND 01221260149	358.70
101.8 · OFF SET PROGRAM01521118823	500.01
Total Checking/Savings	1,458,895.68
Accounts Receivable	
ACCIDENT & INCIDENT REPORTS	-98.33
ANIMAL TAX	-399.60
B & O TAXES	
B & O CURRENT ACCOUNTS	-0.01
B & O DELINQUENT ACCOUNTS	-18.00
B & O TAXES - Other	-261,968.33
Total B & O TAXES	-261,986.34
BANK DEPOSIT CORRECTIONS	-925.00
BUSINESS LICENSE.	-3,173.04
CERTIFIEDS	-6.11
EXCISE TAX	-5,922.35
FINES, FEES & COURT COST	5,171.27
Fire Dept MVA Response	-100.00
IRP FEE FOR INTERSTATE TRUCKS	-9,972.17
MISCELLANEOUS	-70.00
MISCELLANOUS PERMITS	-5.50
MUNICIPAL FEES	-29,360.40
PAID PARKING	-4,329.36
PARKING VIOLATIONS.	-160.00
PENALTY/LATE FEE	1,816.36
PERMITS	-266.00
PROPERTY TAXES	-29,259.05
REIMBURSEMENTS.	-1,619.38
Rental Inspection	-300.00
STATE GRANTS	-2,700.00
Use Tax Receivable	-140,531.89
UTILITY TAX	-1,572.87
WVTREASURY LVL CREDIT	-2,969.90
Total Accounts Receivable	-488,739.66
Other Current Assets	
DUE FROM - FIRE PENSION	35,739.95
DUE FROM - POLICE PENSION	34,515.04
Firement Pension Account	1,306,437.63
Policeman Pension Fund	1,543,358.67
106 · PETTY CASH FUND	247.00
12000 · UNDEPOSITED FUNDS	17,754.84
Total Other Current Assets	2,938,053.13
Total Current Assets	3,908,209.15
Fixed Assets	
131-1 · BUILDING-CITY HALL	225.00
131-2 · BUILDING-STREET DEPT	-234.49
131-4 · S/D AUTOMOBILES	14,568.00
133.1 · EQUIPMENT-POLICE	7,177.00
133.2 · STREETS & HWY M & R EQUIPMEN	37,961.00
133.3 · CITY HALL - EQUIPMENT	19,183.62

CITY OF WESTON
Balance Sheet
 As of November 30, 2021

	Nov 30, 21
Total Fixed Assets	78,880.13
TOTAL ASSETS	3,987,089.28
LIABILITIES & EQUITY	
Liabilities	
Current Liabilities	
Accounts Payable	
201 · ACCOUNTS PAYABLE	90,916.39
221 · FICA TAXES PAYABLE	-29,464.31
223 · STATE TAXES W/H PAYABLE	1,388.00
224 · CPRB EMPLOYEE W/H	-5,439.16
225 · PEIA Insurance w/h	-60,906.16
227 · GARNISHMENTS W/H	-428.52
228 · UNEMPLOYMENT COMP PAYABLE	1,691.66
229 · WORKERS COMP PAYABLE	330.62
Total Accounts Payable	-1,911.48
Credit Cards	
Fifth Third Bank Purchasing Car	-59,908.88
Total Credit Cards	-59,908.88
Other Current Liabilities	
224.1 · FIREMEN PENSION W/H	36,648.27
224.2 · POLICE PENSION E/H	32,800.07
224.3 · CPRS RETIREMENT W/H	1,527.72
225.1 · PEIA W/H	-86,799.88
239 · DEFERRED REVENUES	2,844.00
250 · PAYROLL DEDUCTIONS	
225.2 · Optional Life Insurance W/H	-2,845.30
225.3 · Dependence Life Insurance	247.14
225.4 · Supplemental Insurance	13,207.59
227.2 · Municipal Fee-Employee w/h	737.50
Total 250 · PAYROLL DEDUCTIONS	11,346.93
260 · Employee Reimbursement Payable	-35.00
Total Other Current Liabilities	-1,667.89
Total Current Liabilities	-63,488.25
Total Liabilities	-63,488.25
Equity	
30000 · Opening Balance Equity	
10 · coal severance fund	6,435.12
30000 · Opening Balance Equity - Other	2,089,872.33
Total 30000 · Opening Balance Equity	2,096,307.45
32000 · Unrestricted Net Assets	717,441.28
Net Income	1,236,828.80
Total Equity	4,050,577.53
TOTAL LIABILITIES & EQUITY	3,987,089.28

CITY OF WESTON
Balance Sheet
As of November 30, 2021

	Nov 30, 21	Nov 30, 20	% Change
ASSETS			
Current Assets			
Checking/Savings			
101-10 · COAL SEVERANCE 01521008409	0.00	14,714.79	-100.0%
101.1 · GENERAL FUNDS 01521008454	1,496,996.02	1,042,149.61	43.7%
101.2 · PAYROLL ACCOUNT 01521008506	-40,450.09	-34,029.33	-18.9%
101.3 · RAINY DAY FUND 01521224364	995.16	995.16	0.0%
101.4 · POLICE EQUIPMENT 01521101076	495.88	495.88	0.0%
101.75 · POLICE K-9 FUND 01221260149	358.70	358.70	0.0%
101.8 · OFF SET PROGRAM01521118823	500.01	500.01	0.0%
Total Checking/Savings	1,458,895.68	1,025,184.82	42.3%
Accounts Receivable			
ACCIDENT & INCIDENT REPORTS	-98.33	-98.33	0.0%
ANIMAL TAX	-399.60	-399.60	0.0%
B & O TAXES			
B & O CURRENT ACCOUNTS	-0.01	-0.01	0.0%
B & O DELINQUENT ACCOUNTS	-18.00	-18.00	0.0%
B & O TAXES - Other	-261,968.33	-254,044.03	-3.1%
Total B & O TAXES	-261,986.34	-254,062.04	-3.1%
BANK DEPOSIT CORRECTIONS	-925.00	-925.00	0.0%
BUSINESS LICENSE.	-3,173.04	-3,168.04	-0.2%
CERTIFIEDS	-6.11	-6.11	0.0%
EXCISE TAX	-5,922.35	-5,590.28	-5.9%
FINES, FEES & COURT COST	5,171.27	5,171.27	0.0%
Fire Dept MVA Response	-100.00	-100.00	0.0%
IRP FEE FOR INTERSTATE TRUCKS	-9,972.17	-9,972.17	0.0%
MISCELLANEOUS	-70.00	-70.00	0.0%
MISCELLANEOUS PERMITS	-5.50	-5.50	0.0%
MUNICIPAL FEES	-29,360.40	-29,303.40	-0.2%
PAID PARKING	-4,329.36	-4,329.36	0.0%
PARKING VIOLATIONS.	-160.00	-160.00	0.0%
PENALTY/LATE FEE	1,816.36	1,816.36	0.0%
PERMITS	-266.00	-211.00	-26.1%
PROPERTY TAXES	-29,259.05	-29,259.05	0.0%
REIMBURSEMENTS.	-1,619.38	-1,619.38	0.0%
Rental Inspection	-300.00	-300.00	0.0%
STATE GRANTS	-2,700.00	-2,700.00	0.0%
Use Tax Receivable	-140,531.89	-140,531.89	0.0%
UTILITY TAX	-1,572.87	-0.87	-180,689.7%
WVTREASURY LVL CREDIT	-2,969.90	-2,969.90	0.0%
Total Accounts Receivable	-488,739.66	-478,794.29	-2.1%
Other Current Assets			
DUE FROM - FIRE PENSION	35,739.95	38,252.09	-6.6%
DUE FROM - POLICE PENSION	34,515.04	29,291.52	17.8%
Firement Pension Account	1,306,437.63	1,306,437.63	0.0%
Policeman Pension Fund	1,543,358.67	1,543,358.67	0.0%
106 · PETTY CASH FUND	247.00	247.00	0.0%
12000 · UNDEPOSITED FUNDS	17,754.84	7,975.87	122.6%
Total Other Current Assets	2,938,053.13	2,925,562.78	0.4%
Total Current Assets	3,908,209.15	3,471,953.31	12.6%
Fixed Assets			
131-1 · BUILDING-CITY HALL	225.00	225.00	0.0%
131-2 · BUILDING-STREET DEPT	-234.49	-234.49	0.0%
131-4 · S/D AUTOMOBILES	14,568.00	14,568.00	0.0%
133.1 · EQUIPMENT-POLICE	7,177.00	7,177.00	0.0%
133.2 · STREETS & HWY M & R EQUIPMEN	37,961.00	37,961.00	0.0%

CITY OF WESTON
Balance Sheet
 As of November 30, 2021

	Nov 30, 21	Nov 30, 20	% Change
133.3 · CITY HALL - EQUIPMENT	19,183.62	19,183.62	0.0%
Total Fixed Assets	78,880.13	78,880.13	0.0%
TOTAL ASSETS	3,987,089.28	3,550,833.44	12.3%
LIABILITIES & EQUITY			
Liabilities			
Current Liabilities			
Accounts Payable			
201 · ACCOUNTS PAYABLE	90,916.39	90,116.39	0.9%
221 · FICA TAXES PAYABLE	-29,464.31	-29,464.31	0.0%
223 · STATE TAXES W/H PAYABLE	1,388.00	1,388.00	0.0%
224 · CPRB EMPLOYEE W/H	-5,439.16	-5,439.16	0.0%
225 · PEIA Insurance w/h	-60,906.16	-60,906.16	0.0%
227 · GARNISHMENTS W/H	-428.52	-428.52	0.0%
228 · UNEMPLOYMENT COMP PAYABLE	1,691.66	1,691.66	0.0%
229 · WORKERS COMP PAYABLE	330.62	330.62	0.0%
Total Accounts Payable	-1,911.48	-2,711.48	29.5%
Credit Cards			
Fifth Third Bank Purchasing Car	-59,908.88	-41,042.97	-46.0%
Total Credit Cards	-59,908.88	-41,042.97	-46.0%
Other Current Liabilities			
224.1 · FIREMEN PENSION W/H	36,648.27	36,584.37	0.2%
224.2 · POLICE PENSION E/H	32,800.07	29,422.65	11.5%
224.3 · CPRS RETIREMENT W/H	1,527.72	-736.76	307.4%
225.1 · PEIA W/H	-86,799.88	-85,931.82	-1.0%
239 · DEFERRED REVENUES	2,844.00	2,844.00	0.0%
250 · PAYROLL DEDUCTIONS			
225.2 · Optional Life Insurance W/H	-2,845.30	-3,723.10	23.6%
225.3 · Dependent Life Insurance	247.14	135.34	82.6%
225.4 · Supplemental Insurance	13,207.59	4,853.28	172.1%
227.2 · Municipal Fee-Employee w/h	737.50	550.00	34.1%
Total 250 · PAYROLL DEDUCTIONS	11,346.93	1,815.52	525.0%
260 · Employee Reimbursement Payable	-35.00	0.00	-100.0%
Total Other Current Liabilities	-1,667.89	-16,002.04	89.6%
Total Current Liabilities	-63,488.25	-59,756.49	-6.2%
Total Liabilities	-63,488.25	-59,756.49	-6.2%
Equity			
30000 · Opening Balance Equity			
10 · coal severance fund	6,435.12	6,435.12	0.0%
30000 · Opening Balance Equity - Other	2,089,872.33	2,959,571.53	-29.4%
Total 30000 · Opening Balance Equity	2,096,307.45	2,966,006.65	-29.3%
32000 · Unrestricted Net Assets	717,441.28	257,100.42	179.1%
Net Income	1,236,828.80	387,482.86	219.2%
Total Equity	4,050,577.53	3,610,589.93	12.2%
TOTAL LIABILITIES & EQUITY	3,987,089.28	3,550,833.44	12.3%

CITY OF WESTON
Transaction Detail by Account
November 2021

Type	Date	Num	Name	Memo	Class	Cir	Split	Amount	Balance
101.1 - GENERAL FUNDS 01521008454									
Bill Pmt -Check	11/01/2021	15425	American Garage Door			*	201 - ACCOUN...	-253.34	-253.34
Bill Pmt -Check	11/01/2021	15426	AT&T Mobility (FirstN...			*	201 - ACCOUN...	-724.00	-977.34
Bill Pmt -Check	11/01/2021	15427	Charles Kirkpatrick			*	201 - ACCOUN...	-592.00	-1,569.34
Bill Pmt -Check	11/01/2021	15428	Dodson Pest Control			*	201 - ACCOUN...	-50.00	-1,619.34
Bill Pmt -Check	11/01/2021	15429	Eagles Construction ...			*	201 - ACCOUN...	-300.00	-1,919.34
Bill Pmt -Check	11/01/2021	15430	Fubar Enterprises			*	201 - ACCOUN...	-722.00	-2,641.34
Bill Pmt -Check	11/01/2021	15431	Greer Industries, Inc.			*	201 - ACCOUN...	-348.20	-2,989.54
Bill Pmt -Check	11/01/2021	15432	Hardman Trucking Inc			*	201 - ACCOUN...	-658.80	-3,648.34
Bill Pmt -Check	11/01/2021	15433	J T Martin			*	201 - ACCOUN...	-105.00	-3,753.34
Bill Pmt -Check	11/01/2021	15434	Kimberly Harrison-Ed...			*	201 - ACCOUN...	-140.42	-3,893.76
Bill Pmt -Check	11/01/2021	15435	KND Cleaning LLC			*	201 - ACCOUN...	-100.00	-3,993.76
Bill Pmt -Check	11/01/2021	15436	LEAF			*	201 - ACCOUN...	-484.85	-4,478.61
Bill Pmt -Check	11/01/2021	15437	Lewis County 911			*	201 - ACCOUN...	-3,300.00	-7,778.61
Bill Pmt -Check	11/01/2021	15438	Lewis County Chamb...			*	201 - ACCOUN...	-150.00	-7,928.61
Bill Pmt -Check	11/01/2021	15439	McCarty's Portable T...			*	201 - ACCOUN...	-80.00	-8,008.61
Bill Pmt -Check	11/01/2021	15440	McNeil & Co.			*	201 - ACCOUN...	-21,748.68	-29,757.29
Bill Pmt -Check	11/01/2021	15441	MISTRAS Group Inc			*	201 - ACCOUN...	-800.00	-30,557.29
Bill Pmt -Check	11/01/2021	15442	Mon Power Electric			*	201 - ACCOUN...	-888.35	-31,445.64
Bill Pmt -Check	11/01/2021	15443	Morgan & Sons			*	201 - ACCOUN...	-2,123.71	-33,569.35
Bill Pmt -Check	11/01/2021	15444	Municipal Home Rule ...	2021 Annual A...		*	201 - ACCOUN...	-2,000.00	-35,569.35
Bill Pmt -Check	11/01/2021	15445	Nate Stansberry.	Reimbursement		*	201 - ACCOUN...	-500.00	-36,069.35
Bill Pmt -Check	11/01/2021	15446	Radcliff's Service Cen...			*	201 - ACCOUN...	-585.97	-36,655.32
Bill Pmt -Check	11/01/2021	15447	Raven Rock			*	201 - ACCOUN...	-85.00	-36,740.32
Bill Pmt -Check	11/01/2021	15448	Stepoe & Johnson, P...			*	201 - ACCOUN...	-262.50	-37,002.82
Bill Pmt -Check	11/01/2021	15449	The Standard Life Ins...			*	201 - ACCOUN...	-2,254.68	-39,257.50
Bill Pmt -Check	11/01/2021	15450	West Virginia Americ...	1028-2100169...		*	201 - ACCOUN...	-34.24	-39,291.74
Bill Pmt -Check	11/01/2021	15451	Weston Sanitary Board.			*	201 - ACCOUN...	-107.67	-39,399.41
Bill Pmt -Check	11/01/2021	15452	WV Dept of Transport...			*	201 - ACCOUN...	-295.32	-39,694.73
Bill Pmt -Check	11/01/2021	15453	Zachary Michael Lopez			*	201 - ACCOUN...	-721.00	-40,415.73
Bill Pmt -Check	11/01/2021	15454	Eagles Construction ...			*	201 - ACCOUN...	-800.00	-41,215.73
Bill Pmt -Check	11/16/2021	15455	American Legal			*	201 - ACCOUN...	-4,784.00	-45,999.73
Bill Pmt -Check	11/16/2021	15456	Breathing Air Systems			*	201 - ACCOUN...	-301.25	-46,300.98
Bill Pmt -Check	11/16/2021	15457	C.J. Products, Inc			*	201 - ACCOUN...	-405.00	-46,705.98
Bill Pmt -Check	11/16/2021	15458	Corey A. Matheny			*	201 - ACCOUN...	-175.00	-46,880.98
Bill Pmt -Check	11/16/2021	15459	DataMax Corporation			*	201 - ACCOUN...	-3,296.42	-50,177.40
Bill Pmt -Check	11/16/2021	15460	Dominion Energy WV			*	201 - ACCOUN...	-298.14	-50,475.54
Bill Pmt -Check	11/16/2021	15461	Encova Insurance			*	201 - ACCOUN...	-3,978.00	-54,453.54
Bill Pmt -Check	11/16/2021	15462	Hart Office			*	201 - ACCOUN...	-57.60	-54,511.14
Bill Pmt -Check	11/16/2021	15463	J F Allen	85650		*	201 - ACCOUN...	-350.52	-54,861.66
Bill Pmt -Check	11/16/2021	15464	J T Martin			*	201 - ACCOUN...	-285.00	-55,146.66
Bill Pmt -Check	11/16/2021	15465	Kimberly Harrison-Ed...			*	201 - ACCOUN...	-115.38	-55,262.04
Bill Pmt -Check	11/16/2021	15466	Lewis County Commi...	Interstate Cont...		*	201 - ACCOUN...	-65.00	-55,327.04
Bill Pmt -Check	11/16/2021	15467	LITTLE ROSE ENTE...			*	201 - ACCOUN...	-180.18	-55,507.22
Bill Pmt -Check	11/16/2021	15468	Michael John Ayoob	Interstate Cont...		*	201 - ACCOUN...	-370.00	-55,877.22
Bill Pmt -Check	11/16/2021	15469	Mon Power Electric			*	201 - ACCOUN...	-5,335.39	-61,212.61
Bill Pmt -Check	11/16/2021	15470	Mountain State Wast...			*	201 - ACCOUN...	-444.94	-61,657.55
Bill Pmt -Check	11/16/2021	15471	P & G Hardware LLC			*	201 - ACCOUN...	-7.45	-61,665.00
Bill Pmt -Check	11/16/2021	15472	Shentel			*	201 - ACCOUN...	-410.57	-62,075.57
Bill Pmt -Check	11/16/2021	15473	Suttle & Stalnaker PL...			*	201 - ACCOUN...	-4,925.00	-67,000.57
Bill Pmt -Check	11/16/2021	15474	West Virginia Americ...			*	201 - ACCOUN...	-580.02	-67,580.59
Bill Pmt -Check	11/16/2021	15475	Weston Democrat, Inc..			*	201 - ACCOUN...	-155.00	-67,735.59
Bill Pmt -Check	11/16/2021	15476	Weston Sanitary Board.			*	201 - ACCOUN...	-66.67	-67,802.26
Bill Pmt -Check	11/16/2021	15477	Zachary Michael Lopez			*	201 - ACCOUN...	-110.00	-67,912.26
Bill Pmt -Check	11/22/2021	15478	Greer Law			*	201 - ACCOUN...	-700.00	-68,612.26
Bill Pmt -Check	11/30/2021	15479	Andrew Darby			*	201 - ACCOUN...	-232.14	-68,844.40
Bill Pmt -Check	11/30/2021	15480	AT&T Mobility (FirstN...	287301322393		*	201 - ACCOUN...	-586.18	-69,430.58
Bill Pmt -Check	11/30/2021	15481	Civil & Environmental...			*	201 - ACCOUN...	-774.04	-70,204.62
Bill Pmt -Check	11/30/2021	15482	Debbie Gump			*	201 - ACCOUN...	-80.56	-70,285.18
Bill Pmt -Check	11/30/2021	15483	J & M Grafix, LLC			*	201 - ACCOUN...	-80.00	-70,365.18
Bill Pmt -Check	11/30/2021	15484	J F Allen	85650		*	201 - ACCOUN...	-345.69	-70,710.87
Bill Pmt -Check	11/30/2021	15485	J&K Lawn Services			*	201 - ACCOUN...	-4,140.00	-74,850.87
Bill Pmt -Check	11/30/2021	15486	LEAF			*	201 - ACCOUN...	-230.88	-75,081.75
Bill Pmt -Check	11/30/2021	15487	Lewis County Printing...	9415-00		*	201 - ACCOUN...	-80.00	-75,161.75
Bill Pmt -Check	11/30/2021	15488	Mon Power Electric			*	201 - ACCOUN...	-41.60	-75,203.35
Bill Pmt -Check	11/30/2021	15489	Quality Home and Off...			*	201 - ACCOUN...	-500.00	-75,703.35
Bill Pmt -Check	11/30/2021	15490	Ray Smith	VOID:		X	201 - ACCOUN...	0.00	-75,703.35
Bill Pmt -Check	11/30/2021	15491	The Standard Life Ins...			*	201 - ACCOUN...	-2,254.68	-77,958.03
Bill Pmt -Check	11/30/2021	15492	Weston Democrat, Inc..			*	201 - ACCOUN...	-1,037.26	-78,995.29
Bill Pmt -Check	11/30/2021	15493	WV Municipal League			*	201 - ACCOUN...	-700.00	-79,695.29
Total 101.1 - GENERAL FUNDS 01521008454								-79,695.29	-79,695.29
TOTAL								-79,695.29	-79,695.29

November Report 2021

Street Department

- **Blacktop patched 5 ton in Ward 1**
- **Worked on salt spreaders replaced the feeder chain, motor chain, and throttle lever**
- **Installed 3 Historical Reading Stands one at City Building, one at the City Parking Lot, and one at the Post Office**
- **Filled a low spot beside sidewalk on Locust Avenue with fill dirt**
- **Helped unload food and supplies to Our Neighbor**
- **Replaced battery and battery holder on Salt Spreader**
- **Installed new Stop Sign and hardware at Crescent Avenue**
- **Cut fallen tree from overhanging head of Main Avenue at the triangle**
- **Trash Duty each week**
- **Checked maintenance on the trucks (greased up joints, checked and topped fluids)**
- **Cut parking meter poles on First Street**
- **Picked up the Rental Sweeper from Charleston**
- **Began sweeping in Ward 4 ending in Ward 1**
- **Removed damaged two-hour parking sign on Water Street**
- **Fixed Stop Sign on Monroe Street in Shady brook**
- **Put more top soil around drain inside of Haleville Cemetery and seeded and mulched**
- **Installed new Stop Sign on Beer Can Alley**
- **Made saw cuts on Cemetery Street and at the City Building**
- **Opened up the drain that runs along Brown Avenue**
- **Delivered pine to the city building for decorations**
- **Installed 2nd Spreader on White GMC**
- **Gene King let us use his bucket truck along with using our own to speed up the process of Christmas Decorations**
- **Removed broken Weston sign at the City Parking Lot**
- **Removed Veteran Banners around town**
- **Built a box for the Veteran Banners and took them to the Town Hub for storage**
- **Hung Christmas Banners on Main Avenue**
- **Hung Curly Qs at Gomart and the Chinese Restaurant**
- **Hung Snow Flakes on Main Avenue**
- **Hung Santa and the Reindeer on Main Avenue**
- **Put up the Christmas Tree at the City Building along with the help of**

the Fire Department and Police Department

- **Three employees came in on the Saturday before Thanksgiving to cut meter poles along Main Avenue and First Street**
- **Installed new toilet at the Street Department**
- **Assisted Jay Hayes with the bucket truck so he could make repairs to the Christmas lights**
- **Decorated the tree at the City Building**
- **Two employees came in on the Friday after Thanksgiving to plug in the Curly Qs, pickup trash, and a different employee came in to turn on the breaker for the Christmas Lights for the parade and also assisted with traffic control for the parade**
- **Fixed drain issue on Cemetery Street by connecting two existing pipes together and replacing a homemade grate with a standard frame and removable grate**
- **Cleaned ditch on Montgomery Alley and filled in potholes with blacktop millings**
- **Cleaned drain on Bennett Avenue**
- **Cleaned the front building at the Street Department**
- **Hauled out dirt from the rental sweeper and hauled it to the old sewer company in Deanville then graded the dirt with the excavator once dumped**
- **Blacktop patched 5 ton in Ward 1**
- **Rental Sweeper swept in Jane Lew**
- **Hung Christmas lights at the City Building**

Blacktop Tonnage for November: 10 ton

Weston Police Department Individual Monthly Activity Log

Year: 2021

Name: Thomas

MONTH	TOTAL HOURS	CALLS	# OF PERSONS ARRESTED	ARRESTS			ROAD VIOLATIONS		REPORTS		S & A HOURS	POLICE HOURS		SPECIALTY HOURS	OTHER HOURS
				Misdemeanor	Felony	Warnings	Citations	Criminal	Accident	PATROL		CI			
													DAILY TOTALS		
January	553.5	123	8	5	5	67	3	15	6	86.5	146	205.5	25	90.5	
February	652	105	4	3	5	101	5	6	1	86	217	203	7	139	
March	595.5	125	13	14	10	96	13	12	13	95	201	184.5	9.5	105.5	
April	773	135	5	4	1	167	21	9	5	142	188	259	25	159	
May	969	152	13	21		206	33	19	13	142	299.5	281	24	202.5	
June	994.5	198	8	10	4	172	22	12	14	174.5	305.5	260	19.5	235	
July	979	209	20	18	10	87	21	17	15	118	312	289	20.5	239.5	
August	766.5	128	9	8	2	101	7	19	12	48	288.5	225		205	
Sept.	742	146	8	9	2	96	4	15	15	69	232.5	246	1	193.5	
October	740	156	13	14	1	104	14	18	14	60.5	223	218	11.5	227	
Nov.	670.5	142	12	10	41	79	7	13	15	70.5	203	201	6	190	
Dec.															
TOTALS	8435.5	1619	113	116	81	1276	150	155	123	1092	2616	2572	149	1986.5	



Chief of Police Josh Thomas
102 West Second Street
Weston, WV 26452

Telephone: 304-269-3207
Fax: 304-269-6128
Email: jpthomas@cityofwestonwv.com

November 2021 Criminal Investigations

Misdemeanors:

1 – Fleeing in a vehicle 11/02/2021 - Arrested
1 – Joyriding 11/04/2021 - Arrested
1 – Obstructing 11/04/2021 – Arrested
1 – Driving Suspended 11/03/2021 – Arrested 11/29/2021 – Arrested
1 – Domestic Assault 11/12/2021 – Arrested
2 – Shoplifting 11/29/2021 – Arrested
1 – Destruction of Property 11/19/2021 – Open 11/20/2021 – ID victim declined
1 – Petit Larceny 11/30/2021 – Arrested

Felonies:

1 – Shoplifting 3 rd Offense 11/17/2021 – Charged
1 – Child Abuse 11/19/2021 – Open
1 – Grand Larceny 11/12/2021 – Open
1 – Credit Card Fraud 11/30/2021

Note some CI's are part of the same incident and only assigned one CI # and will be more than total CI's

Note – The activity reflects a large number of felony arrests in the month of November, this is attributed to the November session of Grand Jury

Investigations carried over from previous month(s)

1 – Malicious Assault (being investigated as murder)

07/04/2021 – Arrested/Still active

3 – Sexual Assault

07/09/2021 – Open

10/06/2021 – Open

10/24/2021 – Open

1 – Grand Larceny

10/08/2021 – Open

1 - Burglary x 2

Stalking

Animal Cruelty x 2

Destruction of Property x 2

10/12/2021

10/18/2021

These are part of the same incident



WESTON FIRE DEPARTMENT
REPORT FOR THE MONTH OF
November 2021
 "On the job 'til the job is done"



TOTAL CALLS
TOTAL MEETINGS & DRILLS
TOTAL CALLS INSIDE THE CITY
TOTAL CALLS OUTSIDE THE CITY

90
4
50
26

66%
34%

TOTAL MUTUAL-AID CALLS
ASSISTS TO JACKSONS MILL
ASSISTS TO JANE LEW
ASSISTS TO MIDWAY
ASSISTS TO PRICETOWN
ASSISTS TO WALKERSVILLE
ASSISTS TO THE SQUAD

47
0
2
0
2
1
42

FROM
FROM
FROM
FROM
FROM
FROM

2
3
0
2
1
0

OUT OF COUNTY CALLS
PAID MAN LEFT THE CITY
TOTAL MILES
TOTAL APPARATUS HOURS
TOTAL MAN HOURS
TOTAL LOSS IN THE CITY
TOTAL LOSS OUTSIDE THE CITY
BURNING PERMITS ISSUED
MVC's INSIDE THE CITY
MVC's OUTSIDE THE CITY
WORKING STRUCTURE FIRES
WORKING AUTO FIRES
WORKING BRUSH FIRES
WORKING FIRES, OTHER

1
1
757.5
47.02
259.96
\$0
\$27,000
32 17
4
6
4
1
1
1

SAVED
SAVED

\$0
\$75,000

ADDITIONAL REMARKS

Attended all fire dept meetings and drills
 Attended county Association meeting at Walkersville Fire Dept
 Assisted with Christmas Parade
 Had air pack testing done
 working on truck specs for future city engine
 working on preplans for large buainess in the city
 working with sharpe hospital on future drill

Weston Fire Dept.

Copy of Copy of Fire and EMS Combined List by Inci

Alarm Date Between {11/01/2021} And {11/30/2021}
and District = "1A "

Incident	Type	Date	Location	Description
21-0001009-0	FIRE	11/01/2021	312 Town Run RD	Outside rubbish, trash or
21-0001011-0	FIRE	11/02/2021	250 Court AVE /CVS	Medical assist, assist EMS
21-0001012-0	FIRE	11/02/2021	120 Bank ST	Medical assist, assist EMS
21-0001013-0	FIRE	11/02/2021	136 Staunton DR /True Leaf	Dispatched & cancelled en
21-0001014-0	FIRE	11/03/2021	W 2nd ST & Gee Lick RD	Motor Vehicle Accident with
21-0001015-0	FIRE	11/03/2021	124 E 1st ST	Dispatched & cancelled en
21-0001016-0	FIRE	11/03/2021	223 John ST	Medical assist, assist EMS
21-0001019-0	FIRE	11/04/2021	124 E 1st ST	Medical assist, assist EMS
21-0001020-0	FIRE	11/04/2021	124 E 1st ST /509	Smoke detector activation
21-0001024-0	FIRE	11/05/2021	251 W 2nd ST	Medical assist, assist EMS
21-0001025-0	FIRE	11/05/2021	111 Cottage AVE	Dispatched & cancelled en
21-0001026-0	FIRE	11/05/2021	140 Minnich ST	Medical assist, assist EMS
21-0001028-0	FIRE	11/06/2021	Alum AVE	Medical assist, assist EMS
21-0001029-0	FIRE	11/06/2021	E 2nd ST E	Medical assist, assist EMS
21-0001031-0	FIRE	11/06/2021	4 Center AVE	Smoke scare, odor of smoke
21-0001032-0	FIRE	11/07/2021	231 Olive ST	Medical assist, assist EMS
21-0001034-0	FIRE	11/07/2021	274 W 4th ST	Medical assist, assist EMS
21-0001036-0	FIRE	11/08/2021	650 Craig ST	Smoke detector activation
21-0001037-0	FIRE	11/08/2021	43 Riverview Circle	Medical assist, assist EMS
21-0001038-0	FIRE	11/08/2021	43 Riverview Circle	Medical assist, assist EMS
21-0001039-0	FIRE	11/08/2021	311 Main AVE	Medical assist, assist EMS
21-0001040-0	FIRE	11/09/2021	650 Craig ST /101	Dispatched & cancelled en
21-0001041-0	FIRE	11/09/2021	358 Court AVE	Medical assist, assist EMS
21-0001042-0	FIRE	11/09/2021	433 Charles ST	Medical assist, assist EMS
21-0001043-0	FIRE	11/09/2021	339 US Highway 33 E	Medical assist, assist EMS
21-0001044-0	FIRE	11/10/2021	137 Mulberry AVE	Electrical wiring/equipment
21-0001045-0	FIRE	11/10/2021	124 E 1st ST /Criss Manor/404	Medical assist, assist EMS
21-0001046-0	FIRE	11/10/2021	470 Broad ST	Medical assist, assist EMS
21-0001050-0	FIRE	11/11/2021	635 Court AVE	Medical assist, assist EMS
21-0001052-0	FIRE	11/12/2021	112 W 7th ST	Power line down
21-0001053-0	FIRE	11/13/2021	159 John ST	Medical assist, assist EMS
21-0001054-0	FIRE	11/13/2021	US Highway 33 E & Market Place Mall	Motor Vehicle Accident with
21-0001057-0	FIRE	11/14/2021	215 Bland ST	Medical assist, assist EMS
21-0001058-0	FIRE	11/14/2021	W 4th ST & N River AVE	Dispatched & cancelled en
21-0001059-0	FIRE	11/14/2021	650 Craig ST /Weston Commons/110	Dispatched & cancelled en
21-0001061-0	FIRE	11/15/2021	251 W 2nd ST	Medical assist, assist EMS

**Alarm Date Between {11/01/2021} And {11/30/2021}
and District = "1A "**

Incident	Type	Date	Location	Description
21-0001066-0	FIRE	11/18/2021	US Highway 33 E & Market Place Mall	Motor Vehicle Accident with
21-0001068-0	FIRE	11/19/2021	Berlin RD & US Highway 33 E	Motor Vehicle Accident with
21-0001070-0	FIRE	11/19/2021	561 Broad ST	Medical assist, assist EMS
21-0001071-0	FIRE	11/19/2021	215 Bland ST	Medical assist, assist EMS
21-0001073-0	FIRE	11/21/2021	203 W 6th ST	Medical assist, assist EMS
21-0001074-0	FIRE	11/22/2021	39 Berlin RD /SHEETZ	Overheated motor
21-0001075-0	FIRE	11/22/2021	159 John ST	Medical assist, assist EMS
21-0001076-0	FIRE	11/23/2021	852 Winter AVE	Medical assist, assist EMS
21-0001079-0	FIRE	11/24/2021	765 Camden AVE	Medical assist, assist EMS
21-0001083-0	FIRE	11/25/2021	765 Camden AVE	Medical assist, assist EMS
21-0001084-0	FIRE	11/25/2021	277 Rada AVE	Medical assist, assist EMS
21-0001085-0	FIRE	11/26/2021	838 Kuntz ST	Medical assist, assist EMS
21-0001087-0	FIRE	11/26/2021	707 W 2nd ST	Medical assist, assist EMS
21-0001088-0	FIRE	11/26/2021	569 W 2nd ST	Medical assist, assist EMS
21-0001091-0	FIRE	11/28/2021	569 W 2nd ST	Medical assist, assist EMS
21-0001093-0	FIRE	11/28/2021	117 E 7th ST	Medical assist, assist EMS
21-0001095-0	FIRE	11/29/2021	321 Cottage AVE	Medical assist, assist EMS
21-0001096-0	FIRE	11/29/2021	2262 US Highway 33 E	Motor vehicle accident with

Total Incident Count 54

Weston Fire Dept.

Copy of Copy of Fire and EMS Combined List by Inci

Alarm Date Between {11/01/2021} And {11/30/2021}
and District = "1B "

Incident	Type	Date	Location	Description
21-0001010-0	FIRE	11/01/2021	MM Interstate 79	Motor Vehicle Accident with
21-0001017-0	FIRE	11/04/2021	98 MM Interstate 79	Motor Vehicle Accident with
21-0001018-0	FIRE	11/04/2021	8000 US Highway 33 E	Power line down
21-0001021-0	FIRE	11/05/2021	3308 Georgetown RD	Building fire
21-0001023-0	FIRE	11/05/2021	708 Jennings Run RD	Power line down
21-0001027-0	FIRE	11/05/2021	200 Mountain Retreat DR	Dispatched & cancelled en
21-0001030-0	FIRE	11/06/2021	MM Interstate 79	Dispatched & cancelled en
21-0001033-0	FIRE	11/07/2021	US Highway 19 S & Georgetown RD	Motor Vehicle Accident with
21-0001035-0	FIRE	11/08/2021	97.8 MM Interstate 79	Road freight or transport
21-0001048-0	FIRE	11/11/2021	150 Market Place Mall	Brush or brush-and-grass
21-0001055-0	FIRE	11/13/2021	140 Thorn Hill RD	Medical assist, assist EMS
21-0001056-0	FIRE	11/14/2021	US Highway 33 E & Wilson Siding RD	Motor Vehicle Accident with
21-0001060-0	FIRE	11/15/2021	1739 US Highway 33 W	Power line down
21-0001062-0	FIRE	11/16/2021	257 Smith Run RD	No Incident found on arrival
21-0001063-0	FIRE	11/16/2021	92 MM Interstate 79	Dispatched & cancelled en
21-0001069-0	FIRE	11/19/2021	509 Berlin RD	Medical assist, assist EMS
21-0001072-0	FIRE	11/20/2021	105 MM Interstate 79	Dispatched & cancelled en
21-0001077-0	FIRE	11/23/2021	110 Berlin RD	Medical assist, assist EMS
21-0001078-0	FIRE	11/23/2021	84 MM Interstate 79	Dispatched & cancelled en
21-0001080-0	FIRE	11/24/2021	Georgetown RD & Little Skin Creek	No Incident found on arrival
21-0001081-0	FIRE	11/25/2021	32 Quarry Glen /101	Medical assist, assist EMS
21-0001082-0	FIRE	11/25/2021	32 Quarry Glen /101	Medical assist, assist EMS
21-0001086-0	FIRE	11/26/2021	1536 Gladly Fork RD	Public service
21-0001090-0	FIRE	11/27/2021	92 MM Interstate 79	Motor vehicle accident with
21-0001092-0	FIRE	11/28/2021	Pine Run RD	Dispatched & cancelled en
21-0001097-0	FIRE	11/29/2021	89.5 MM Interstate 79	Motor Vehicle Accident with

Total Incident Count 26

Weston Fire Dept.

Incident Type Report (Summary)

Alarm Date Between {11/01/2021} And {11/30/2021}

Incident Type	Count	Pct of Incidents	Total Est Loss	Pct of Losses
1 Fire				
111 Building fire	4	4.44%	\$25,000	92.59%
132 Road freight or transport vehicle fire	1	1.11%	\$2,000	7.40%
142 Brush or brush-and-grass mixture fire	1	1.11%	\$0	0.00%
151 Outside rubbish, trash or waste fire	1	1.11%	\$0	0.00%
	<u>7</u>	<u>7.77%</u>	<u>\$27,000</u>	<u>100.00%</u>
3 Rescue & Emergency Medical Service Incident				
311 Medical assist, assist EMS crew	41	45.55%	\$0	0.00%
322 Motor vehicle accident with injuries	3	3.33%	\$0	0.00%
324 Motor Vehicle Accident with no injuries	12	13.33%	\$0	0.00%
	<u>56</u>	<u>62.22%</u>	<u>\$0</u>	<u>0.00%</u>
4 Hazardous Condition (No Fire)				
440 Electrical wiring/equipment problem, Other	1	1.11%	\$0	0.00%
442 Overheated motor	1	1.11%	\$0	0.00%
444 Power line down	4	4.44%	\$0	0.00%
	<u>6</u>	<u>6.66%</u>	<u>\$0</u>	<u>0.00%</u>
5 Service Call				
553 Public service	1	1.11%	\$0	0.00%
	<u>1</u>	<u>1.11%</u>	<u>\$0</u>	<u>0.00%</u>
6 Good Intent Call				
611 Dispatched & cancelled en route	15	16.66%	\$0	0.00%
622 No Incident found on arrival at dispatch	2	2.22%	\$0	0.00%
651 Smoke scare, odor of smoke	1	1.11%	\$0	0.00%
	<u>18</u>	<u>20.00%</u>	<u>\$0</u>	<u>0.00%</u>
7 False Alarm & False Call				
733 Smoke detector activation due to	2	2.22%	\$0	0.00%
	<u>2</u>	<u>2.22%</u>	<u>\$0</u>	<u>0.00%</u>

Total Incident Count: 90

Total Est Loss: \$27,000

Weston Fire Dept.

Aid Responses by Department (Summary)

Alarm Date Between {11/01/2021} And {11/30/2021}

Type of Aid	Count
10 Out of County	
Mutual aid given	1
	<hr/>
	1
2 Jane Lew Volunteer Fire Department	
Automatic aid received	3
Automatic aid given	2
	<hr/>
	5
3 Pricetown Volunteer Fire Department	
Automatic aid received	2
Automatic aid given	2
	<hr/>
	4
4 Walkersville Volunteer Fire Department	
Mutual aid given	1
Automatic aid given	1
	<hr/>
	2
5 Jackson's Mill Volunteer Fire Department	
Automatic aid received	2
	<hr/>
	2
8 Lewis County Emergency Ambulance Authority	
Automatic aid received	1
Mutual aid given	3
Automatic aid given	38
	<hr/>
	42



MIKE STARETT
CODE/BUILDING/ZONING ENFORCEMENT OFFICER
MONTHLY REPORT
FOR NOVEMBER 2021

CONDEMNATION: 5

WARD I- 1
WARD II- 0
WARD II-0
WARD IV- 4

CORRECTIVE ORDER: 6

WARD I- 1
WARD II- 1
WARD III- 0
WARD IV- 4

WARNINGS: 3

WARD I- 2
WARD II- 1
WARD III- 0
WARD IV- 0



DEMOLITION: 2

5 HEATH COURT

19 HEATH COURT

WORKING ON 1 IN SHADY BROOK AND 1 ON WEST SECOND STREET.

BUILDING PERMITS: 13

WORKED WITH 464 BROAD STREET ON CLEAN UP THE PROGRESS - IS ONE ROOM LEFT TO CLEAN.
(OWNER IS INCARCERATED).

WORKED ON CHRISTMAS LIGHTS WITH STREET DEPT. AND ON STREET DEPT ROOF.

WORKED WITH DEP AND DHHR ON 4 HOUSES BEING TORN DOWN.

WORKING WITH CPS ON 2 HOUSES THAT ARE UNSANITARY AND HAS KIDS LIVING THERE.

WORKING WITH ADULT CPS ON 1 HOUSE FOR SANITATION.

WORKED WITH BZA ON UNITED BANK PROJECT.

WORKED WITH CODE APPEALS ON 17 CENTER.

WORKING WITH MUNICIPAL COURT ON 469 BROAD.



Business License Report

For the Month of

November 2021

<u>Name</u>	<u>Occupation</u>	<u>Date</u>
Golden Vantage Contracting 943 Left Laurel Lick RD Weston, WV 26452 (304) 269-6790	Contractor	11-7-2021
D1 Resources, Inc 10428 SE Hwy 26 Galena, KS 66739 (620) 461-0465	Contractor	11-17-2021
McKaney Guttering Jason McKaney 2602 Murphy Creek Road Weston, WV 26452 304-884-4858	All Other	11-17-2021
Clayton Homes 1865 Beverly Pike Elkins, WV 26241 (304) 636-6900	Contractor Corporation w/\$5000 or more in capital	11-24-2021
GY6 Barber Co., LLC Robert Eiler III 140 Main Avenue Weston, WV 26452 (304)517-3550	All Other	11-24-2021
Paul's Custom Construction Paul Jeffries 387 High Street Jane Lew, WV 26378	Contractor	11-29-2021



Hardman Trucking Inc. 29 Sauls Run Road Weston, WV 26452 (304) 269-5240	All Other	11-29-2021
Small Town Handyman LLC Oliver Caple 5 Bailey Avenue Weston, WV 26452 (304) 695-6005	Handyman	11-30-2021
Alford Home Solutions Inc. 6316 MacCorkle Avenue St. Albans, WV 25177 (304) 768-2135	Contractor	11-30-2021
United Contracting Inc. Darell Burgess 7407 Kesling Mill Road Buckhannon, WV 26201 304-472-0122	Contractor	11-30-2021

9. Old Business

BID SHEET
CITY OF WESTON, WV
Demolition of Vacant Structures

PRICING VALID THRU JUNE 30, 2022

Bidders should attach all required documents as detailed in the Request for Bids and Bid Specifications to this form as their submittal. Bids missing the required documents shall be considered unresponsive.

Address	Demolition	Material Removal	Fill	Reclamation	Total
140 Mulberry St.	3,000	6,000	500	500	10,000
251 South Main St.	4	4	4	4	10,000
241 South Main St.	4	4	4	4	10,000
240 High St.	5,000	9,000	4	4	15,000. ^{ed}

The undersigned hereby states that he/she read and understands and agrees to the accompanying, Request for Bids, Specifications and Bid Sheet and submits their quotation accordingly.

Contractor PMI/SAFE Co Phone 304 269-5070

WV Contractors License Number WV 051429

Address 71 Asylum Dr Weston W.V

Licensed Asbestos Supervisor Anthony Jordan

Name and Title of Agent Joe Jordan Agent

Signature of Authorized Agent Joe Jordan Date 8/21/21

City of Weston (Bid is accepted once approved by Council and an authorized representative of the City signs below)

Name and Title _____

Signature _____ Date _____

The City reserves the right to reject any proposals received, to negotiate with any qualified source, to waive any formality and any technicalities or to cancel this request for bids in part or in its entirety if in the interest of the City. This solicitation of bids in no way obligates the City to award a contract. The City also reserves the right to add or subtract from the quantities of work within reason and not negotiate a change in price.

City of Weston, WV

Demolition of Vacant Structures Addendum No. 1

October 27th, 2021

This notice serves as an Addendum No. 1 to the Demolition of Vacant Structures Bid Package published by the City of Weston, WV.

This addendum serves to extend the receiving of bids until 4 p.m. on Friday October 29th, 2021.

The addendum also serves as an answer to questions posed by Contractors to be shared with all prospective bidders. The questions and corresponding answers are shown below:

1. Who will be responsible to perform the asbestos inspections as required by the WVDEP?

The City of Weston will be responsible to supply and pay for the required asbestos reports.

2. Which landfill will be utilized in the disposal of all demolition materials?

Meadowfill Landfill will be utilized to dispose of all waste materials. The landfill is located at 1488 Dawson Drive in Bridgeport.

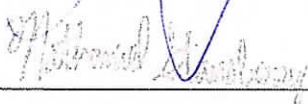
Nate Stansberry, City Manager

**BID SHEET
CITY OF WESTON, WV
Demolition of Vacant Structures**

PRICING VALID THRU JUNE 30, 2022

Bidders should attach all required documents as detailed in the Request for Bids and Bid Specifications to this form as their submittal. Bids missing the required documents shall be considered unresponsive.

Address	Demolition	Material Removal	Fill	Reclamation	Total
140 Mulberry St.	\$4,550	\$2,250	\$2,250	\$3,700	\$12,750
251 South Main St.	\$2,050	\$1,800	\$2,250	\$3,700	\$9,800
241 South Main St.	\$3,300	\$1,800	\$2,250	\$3,700	\$11,050
270 High St.	\$4,550	\$1,800	\$2,250	\$3,700	\$12,300

The undersigned hereby states that he/she read and understands and agrees to the accompanying, Request for Bids, Specifications and Bid Sheet and submits their quotation accordingly.

Contractor Enviroclean LLC Phone (304) 623-6770
 WV Contractors License Number WV052655
 Address PO Box 336 West Milford, WV 26451
 Licensed Asbestos Supervisor Kenneth N List
 Name and Title of Agent Alex Loay - Field Supervisor
 Signature of Authorized Agent *Alex Loay* Date 10-28-2021

City of Weston (Bid is accepted once approved by Council and an authorized representative of the City signs below)
 Name and Title _____ Signature _____
 _____ Date _____

The City reserves the right to reject any proposals received, to negotiate with any qualified source, to waive any formality and any technicalities or to cancel this request for bids in part or in its entirety if in the interest of the City. This solicitation of bids in no way obligates the City to award a contract. The City also reserves the right to add or subtract from the quantities of work within reason and not negotiate a change in price.

City of Weston, WV

Demolition of Vacant Structures Addendum No. 1

October 27th, 2021

This notice serves as an Addendum No. 1 to the Demolition of Vacant Structures Bid Package published by the City of Weston, WV.

This addendum serves to extend the receiving of bids until 4 p.m. on Friday October 29th, 2021.

The addendum also serves as an answer to questions posed by Contractors to be shared with all prospective bidders. The questions and corresponding answers are shown below:

1. Who will be responsible to perform the asbestos inspections as required by the WVDEP?

The City of Weston will be responsible to supply and pay for the required asbestos reports.

2. Which landfill will be utilized in the disposal of all demolition materials?

Meadowfill Landfill will be utilized to dispose of all waste materials. The landfill is located at 1488 Dawson Drive in Bridgeport.

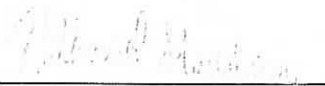

Nate Stansberry, City Manager





AGENDA ITEM: **9D**

MEMORANDUM

To: Mayor and Council

From: Nate Stansberry, City Manager

Date: December 6, 2021

Re: Extension of Street Department Temp Employee Oldaker

The winter construction season and end year wrap activities are continuing. The City Manager is also still working on a financial projection for the creation of trainee street department laborer. It is forecasted that a budget revision will be presented come beginning of the year and at that time I'd like to make a fully informed recommendation at this time.

I'm requesting that Mr. Oldaker be extended in his current capacity until Friday, January 14th unless a full recommendation is presented to Council and action is taken.

10. New Business

**A 2021 Ordinance Authorizing the Sale/Transfer of City Property Related to a
West Virginia Department of Transportation, Division of Highways Bridge
Project, State Project No. S321-N 16/70-0.02 00**

WHEREAS, the West Virginia Department of Transportation, Division of Highways ("DOH") has requested that the City of Weston convey to the DOH a non-controlled access right of way, for public road purposes as designated in the property description(s) of the proposed deed attached to this ordinance;

WHEREAS said property can be described as: "the property needed for the bridge between Haleville and Shadybrook" or similar language;

WHEREAS, WV Code §8-11-3(6) requires City Council of Weston to pass an ordinance to sell property belonging to the City of Weston;

WHEREAS, the City of Weston intends for this ordinance to be the authorization for giving the DOH the right of way that the DOH is requesting concerning State Project No S321-N 16/70-0.02 00, concerning the property description(s) of the proposed deed attached to this ordinance;

Any ordinances in conflict with this ordinance are hereby repealed;

That if any part of this ordinance for any reason be declared unconstitutional, or otherwise invalid, the decision of the Court shall not effect the validity of any remaining part.

This ordinance shall take effect on the day after the Second reading of this ordinance

First Reading _____

Second Reading _____

Mayor

City Clerk

Mail to: District Right of Way Agent
WV Department of Transportation, Division of Highways
District Seven Right of Way Section
P.O. Box 1228 Weston, West Virginia 26452

PROJECT NO.: S321-N 16/70-0.02 00
STP-1670(002)DTC
PARCEL: 7

THIS DEED, made this 1st day of November 2021, by and **THE CITY OF WESTON**, hereinafter called Grantor, and the **WEST VIRGINIA DEPARTMENT OF TRANSPORTATION, DIVISION OF HIGHWAYS**, hereinafter called Grantee. **WITNESSETH:** That for and in consideration of the sum of **ONE DOLLARS (\$1.00)**, cash in hand paid, the receipt and sufficiency of which are hereby acknowledged, the Grantor does hereby **GRANT** and **CONVEY** unto the Grantee, free of all encumbrances and with covenants of **GENERAL WARRANTY**, a noncontrolled access right of way, for public road purposes, over, through, across and upon those certain tracts or parcels of land situate in Freemans Creek City District, Lewis County, West Virginia, and shown and designated upon plans of the West Virginia Department of Transportation, Division of Highways, for the project hereinafter designated, a copy of which said plans is of record in the Office of the Clerk of the County Commission of the aforesaid County, which said right of way is more particularly bounded and described as follows:

NON-CONTROLLED ACCESS RIGHT OF WAY

BEGINNING at a point in the eastern existing right of way line of Lewis County Route 1, said point being in the eastern proposed noncontrolled access right of way line of Lewis County Route 1 and 15 feet radially right of Lewis County Route 1 centerline at Station 106+57, Project S321-N 16/70-0.02 00, STP-1670(002)DTC, Lewis County, West Virginia;

thence, southeasterly, with said proposed noncontrolled access right of way line 24 feet, more or less, to a point 36 feet radially right of centerline at Station 106+44;

thence, southerly, continuing with said proposed noncontrolled access right of way line 116 feet, more or less, to a point 35 feet right of and at right angle to centerline at Station 105+26;

thence, easterly, continuing with said proposed noncontrolled access right of way line 10 feet, more or less, to a point 45 feet right of and at right angle to centerline at Station 105+26;

thence, southerly, continuing with said proposed noncontrolled access right of way line 14 feet, more or less, to a point 45 feet right of and at right angle to centerline at Station 105+12;

thence, westerly, continuing with said proposed noncontrolled access right of way line 11 feet, more or less, to a point 34 feet right of and at right angle to centerline at Station 105+12;

thence, southerly, continuing with said proposed noncontrolled access right of way line 7 feet, more or less, to a point 34 feet right of and at right angle to centerline at Station 105+05;

thence, southerly, continuing with said proposed noncontrolled access right of way line 172 feet, more or less, to a point 65 feet left of and at right angle to proposed Lewis County Route N16/70 centerline at Station 50+46;

thence, easterly, continuing with said proposed noncontrolled access right of way line 11 feet, more or less, to a point in the western bank of West Fork River, said point being 65 feet right of and at right angle to centerline at Station 50+57;

thence, southerly, meandering upstream with said river 125 feet, more or less, to a point 60 feet right of and at right angle to centerline at Station 50+54;

thence, southerly, with said proposed noncontrolled access right of way line 78 feet, more or less, to a point 132 feet right of and at right angle to centerline at Station 50+47;

thence, southeasterly, continuing with said proposed noncontrolled access right of way line 274 feet, more or less, to a point in the eastern existing right of way line of Lewis County Route 1, said point being 15 feet radially right of Lewis County Route 1 centerline at Station 98+41;

thence, northerly, meandering with said existing right of way line 805 feet, more or less, to the place of beginning and containing 15,601 square feet, more or less.

The tract of land hereinabove described is a portion of that same real estate conveyed unto The City of Weston, from Rose V. Forinash, Executrix of the Will of Sallie T. Vandervort, deceased, by deed dated September 23, 1944, of record in the Office of the Clerk of the County Commission of Lewis County, in Deed Book 171 at Page 351.

The Grantor(s) do hereby release the Grantee from all liability for any and all claims which might have been legally asserted against the Grantee as just compensation in an eminent domain proceeding prosecuted by it against the Grantor(s) under its power to take and damage private property for public highway purposes.

This conveyance includes such width and depth as set forth in Chapter 17, Article 2A, Section 17 of the Official Code of West Virginia of 1931, as amended, together with all materials therein.

The Grantor(s), under penalties of perjury, declare that he/she/it/they are residents of the State of West Virginia, and therefore exempt from the tax withholding requirements of W. Va. Code §11-21-71b.

This is a transfer exempt from West Virginia excise taxes on property transfers under Chapter 11, Article 22, Sections 1 and 2 of the Official Code of West Virginia of 1931, as amended.

WITNESS the following signature and seal.

THE CITY OF WESTON

By Its _____

STATE OF WEST VIRGINIA,

COUNTY OF _____, TO WIT:

The foregoing instrument was acknowledged before me this _____ day of

_____, 2021 by THE CITY OF WESTON. by

_____ its _____ of THE CITY OF WESTON.

My Commission expires _____.

This instrument was prepared by: Legal Section Right of Way Division, Division of Highways.

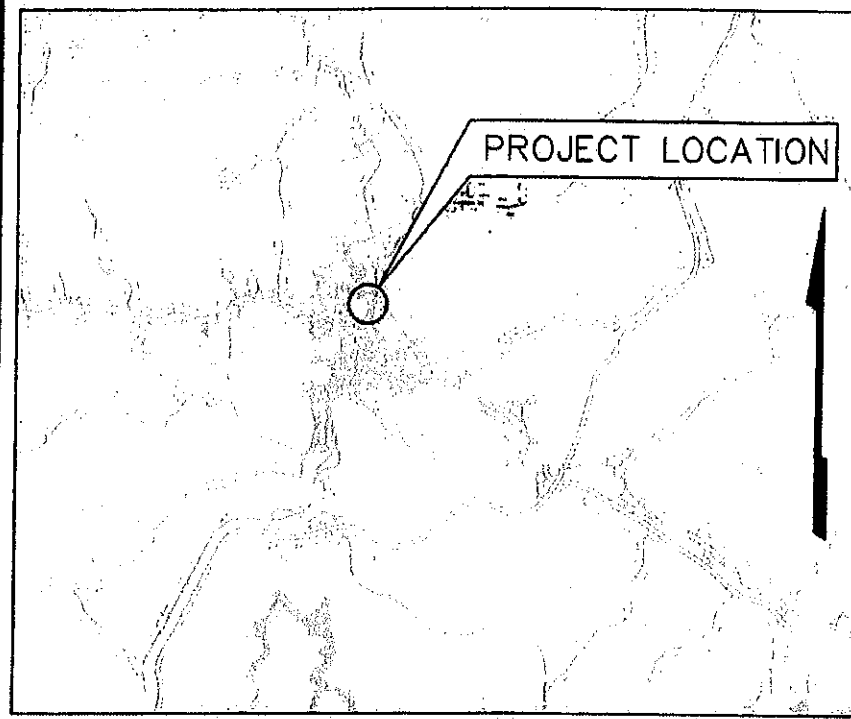

WEST VIRGINIA
DEPARTMENT OF TRANSPORTATION
DIVISION OF HIGHWAYS
RIGHT OF WAY PLANS
 OF
STATE HIGHWAY
 FEDERAL PROJECT NO. STP-1670(002)DTC
 STATE PROJECT NO. S321-N 16/70-0.02 00
 COUNTY ROUTE NO. 1
 US ROUTE NO. 19
 WESTON HACKERS CREEK CORP & WESTON FREEMAN CREEK CORP
 LEWIS COUNTY
FOURTH STREET ARCH BRIDGE

R/W PROJECT LENGTH	Station	Station	ft.	mile(s)
	50+27	to 53+10	= 283	= 0.054

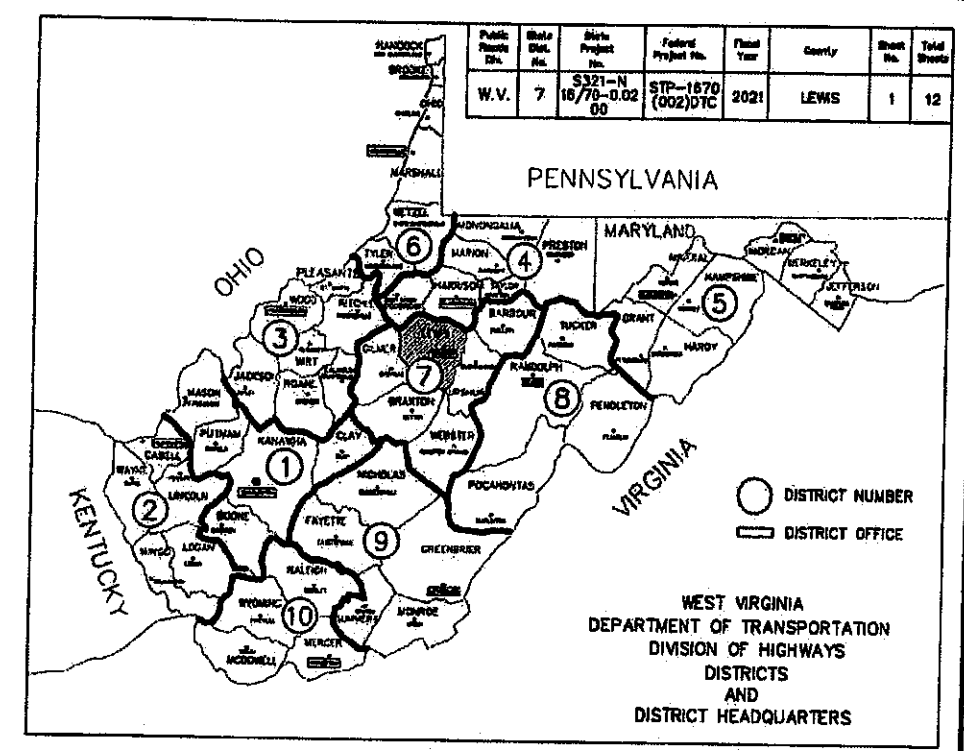

UTILITIES ENCOUNTERED

- WEST VIRGINIA AMERICAN WATER (WATER)
- FIRST ENERGY CORPORATION (ELECTRIC)
- WESTON SANITARY BOARD (SEWER)
- FRONTIER COMMUNICATIONS (TELEPHONE)
- SHENTEL (CABLE)
- DOMINION ENERGY (GAS)
- CSX TRANSPORTATION, INC (RAILROAD)

TYPE OF SUBMISSION

R/W 3

J.B. TURMAN ENGINEERING, PLLC
 P.O. BOX 483
 BARDOURSVILLE WEST VIRGINIA 25304
 www.jbturman.com

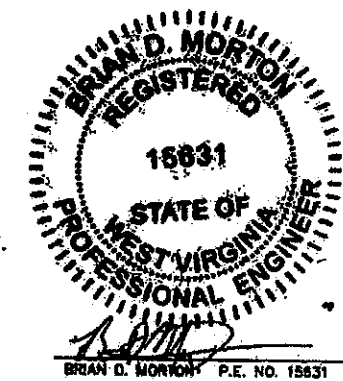

BRIAN D. MORTON P.E. NO. 15831
 DATE: 3/1/21

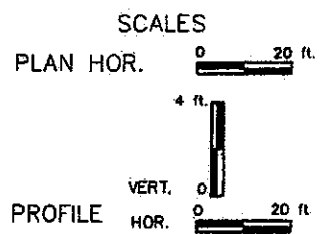

DESIGN DESIGNATION	
A. D. T. 2018	= 3.782
A. D. T. 2036	= 4.161
D. H. V.	= N/A
D.	= N/A
T.	= N/A
V.	= 30 mph
DESIGN EXCEPTIONS:	

- CONVENTIONAL SIGNS**
- STATE LINE
 - COUNTY LINE
 - CORPORATION LINE
 - PROPOSED R/W & EASEMENT LINE
 - EXISTING R/W LINE
 - PROPERTY LINE
 - EXISTING FENCE
 - PROPOSED FENCE
 - EDGE OF STREAM
 - PROPOSED GUARD RAIL
 - EXISTING GUARD RAIL
 - RAILROAD
 - GAS LINE
 - WATER LINE
 - TELEPHONE LINE
 - ELECTRIC LINE
 - TELEPHONE POLE
 - POWER POLE
 - COMBINED POWER AND TELEPHONE POLE
 - TREE
 - SHRUB
 - RIGHT OF WAY MARKER

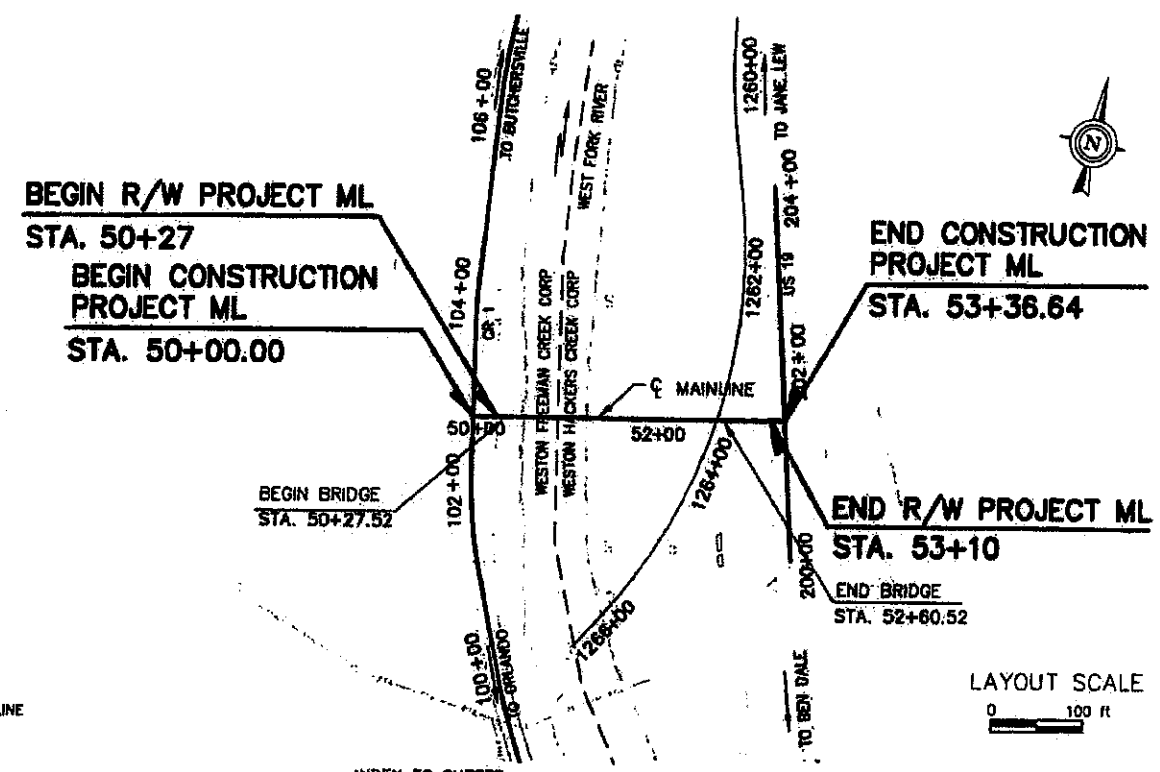

INDEX TO SHEETS

NO.	DESCRIPTION
1	TITLE SHEET
2	OWNERSHIP INDEX
3	PROPERTY MAP
4-6	ROW PLAN SHEETS
7	GEOMETRIC LAYOUT
8-9	TYPICAL SECTIONS
10-12	PROFILE SHEETS

REVISION NUMBER	DATE	BY

I HEREBY CERTIFY THAT THIS IS A CORRECT COPY OF THE PLANS
 OF PROJECT S321-N 16/70-0.02 00, STP-1670(002)DTC

 EXECUTIVE SECRETARY
 3-8 2021

RECOMMENDED:
 PROJECT MANAGER
 RECOMMENDED FOR APPROVAL:
 STATE HIGHWAY ENGINEER
 APPROVED:
 COMMISSIONER OF HIGHWAYS

01 MARCH 2021

OWNERSHIP INDEX																
PARCEL NO.	PLAN SHEET NO.	TITLEHOLDER	TRACT NO.	RECORDED		AREA = Sq. Ft. (Unless noted otherwise)							REMARKS			
				DEED BOOK	PAGE NO.	C/A	NON-C/A	EASEMENT		REMAINING				TOTAL TAKEN	PARCEL TOTAL	
								TYPE	AREA	LEFT	RIGHT	TOTAL				
1	4	JUDY E. TURNER		WB46	316		4903					1.02 AC	1.02 AC	4903	1.13 AC (C)	
				344	133		0.11 AC						0.11 AC			
				391	17											
				672	592											
2	4	SONIA L. MILES AND PAUL D. MILES		760	592		1647				7780	7780	1647	9427 (C)		
3	4, 6	SONIA L. DRESSLER, A/K/A SONIA MILES		672	472		3635				17249	17249	3635	20884 (C)		
4-1	4	STATE OF WEST VIRGINIA, DEPARTMENT OF COMMERCE, DIVISION OF NATURAL RESOURCES							P.E.	8668			8668		STREAM CROSSING (WEST FORK RIVER)	
4-2	4, 5	STATE OF WEST VIRGINIA, DEPARTMENT OF COMMERCE, DIVISION OF NATURAL RESOURCES							T.E.	3619			0		STREAM CROSSING (WEST FORK RIVER)	
5-1	4, 5	CSX TRANSPORTATION, INC.	1				3345						3345		VAL MAP	
			2					T.C.E.	1313							
5-2	4	CSX TRANSPORTATION, INC.					11831						11831		VAL MAP	
6	4, 5	H&M MOTOR COMPANY, INC.		540	42		222						17378	17378	222	17600
7	4, 5, 6	CITY OF WESTON					15601						15601		RIVER BANK	

P.E. DENOTES PERMANENT EASEMENT
T.C.E. DENOTES TEMPORARY CONSTRUCTION EASEMENT
T.E. DENOTES TEMPORARY EASEMENT
N/A DENOTES NON-APPLICABLE

UTILITIES			
STATION	SHEET NO	DESCRIPTION	DISPOSITION
WESTON SANITARY BOARD (SEWER)			
99+89 LT	5	SANITARY SEWER MANHOLE	TO REMAIN
99+38 RT TO 99+89 LT	5	SANITARY SEWER LINE	TO REMAIN
99+38 RT TO 107+18 RT	4, 5, 6	SANITARY SEWER LINE	TO REMAIN
100+00 RT TO 104+93 RT	4, 5, 6	SANITARY SEWER LINE	TO BE RELOCATED BY OWNER
104+93 RT TO 106+61 RT	6	SANITARY SEWER LINE	TO BE RELOCATED BY OWNER
103+39 LT TO 103+48 RT	4	SANITARY SEWER SERVICE LINE	TO BE RELOCATED BY OWNER
104+94 RT	6	SANITARY SEWER MANHOLE	TO BE RELOCATED BY OWNER
107+18 RT	6	SANITARY SEWER MANHOLE	TO REMAIN
FIRST ENERGY CORPORATION (ELECTRIC)			
99+41 LT	5	ELECTRIC POLE #UNKNOWN	TO REMAIN
99+41 LT TO 100+15 LT	5	ELECTRIC LINE	TO BE RELOCATED BY OWNER
100+15 LT	5	ELECTRIC POLE #UNKNOWN	TO BE RELOCATED BY OWNER
100+15 LT TO 102+27 LT	4, 5	ELECTRIC LINE	TO BE RELOCATED BY OWNER
102+27 LT	4	ELECTRIC POLE #UNKNOWN	TO BE RELOCATED BY OWNER
102+27 LT TO 103+95 LT	4, 6	ELECTRIC LINE	TO BE RELOCATED BY OWNER
103+95 LT	6	ELECTRIC POLE #41-621	TO BE RELOCATED BY OWNER
103+95 LT TO 105+57 LT	6	ELECTRIC LINE	TO BE RELOCATED BY OWNER
105+57 LT	6	ELECTRIC POLE #41-620	TO BE RELOCATED BY OWNER
105+57 LT TO 107+08 LT	6	ELECTRIC LINE	TO BE RELOCATED BY OWNER
199+67 RT	4	ELECTRIC POLE #42/9	TO REMAIN
199+67 RT TO 201+07 RT	4	ELECTRIC LINE	TO REMAIN
201+07 RT	4	ELECTRIC POLE #UNKNOWN	TO REMAIN
202+19 RT	4	ELECTRIC POLE WITH GUY WIRE #UNKNOWN	TO REMAIN

UTILITIES			
STATION	SHEET NO	DESCRIPTION	DISPOSITION
FRONTIER COMMUNICATIONS (TELEPHONE)			
199+67 RT TO 201+07 RT	4	TELEPHONE LINE	TO REMAIN
SHENTEL (CABLE)			
199+67 RT TO 201+07 RT	4	CABLE LINE	TO REMAIN
101+00 LT TO 101+60 LT	4, 5	DOMINION ENERGY (GAS)	TO BE RELOCATED BY OWNER

5 OCTOBER 2021

P.O. Box 483
Barboursville, WV 25504
www.jbtengineering.com
304-733-1335



J.B. TURMAN ENGINEERING, PLLC

REVISION NUMBER	SHEET NUMBER	REVISION	DATE	BY

**FOURTH STREET ARCH BRIDGE
CONNECTING CR 1 AND US 19
OVER WEST FORK RIVER**

THE WEST VIRGINIA DEPARTMENT OF TRANSPORTATION
DIVISION OF HIGHWAYS

OWNERSHIP INDEX

PUBLIC ROADS DIV.	STATE DIST. NO.	STATE PROJECT NO.	FEDERAL PROJECT NO.	FISCAL YEAR	COUNTY	SHEET NO.	TOTAL SHEETS
WV	7	S321-N 16/70-0.02 00	STP-1670(002)DTC	2021	LEWS	3	12



THIS PROJECT IS LOCATED ENTIRELY IN THE CITY OF WESTON

END WALL STA. 104+40.00
 BEGIN BRIDGE STA. 50+28.02
 BEGIN WALL STA. 103+20.00
 BEGIN R/W PROJECT ML STA. 50+27
 BEGIN CONSTRUCTION PROJECT ML STA. 50+00.00
 END BRIDGE STA. 52+60.52
 END R/W PROJECT ML STA. 53+10
 END CONSTRUCTION PROJECT ML STA. 53+36.64

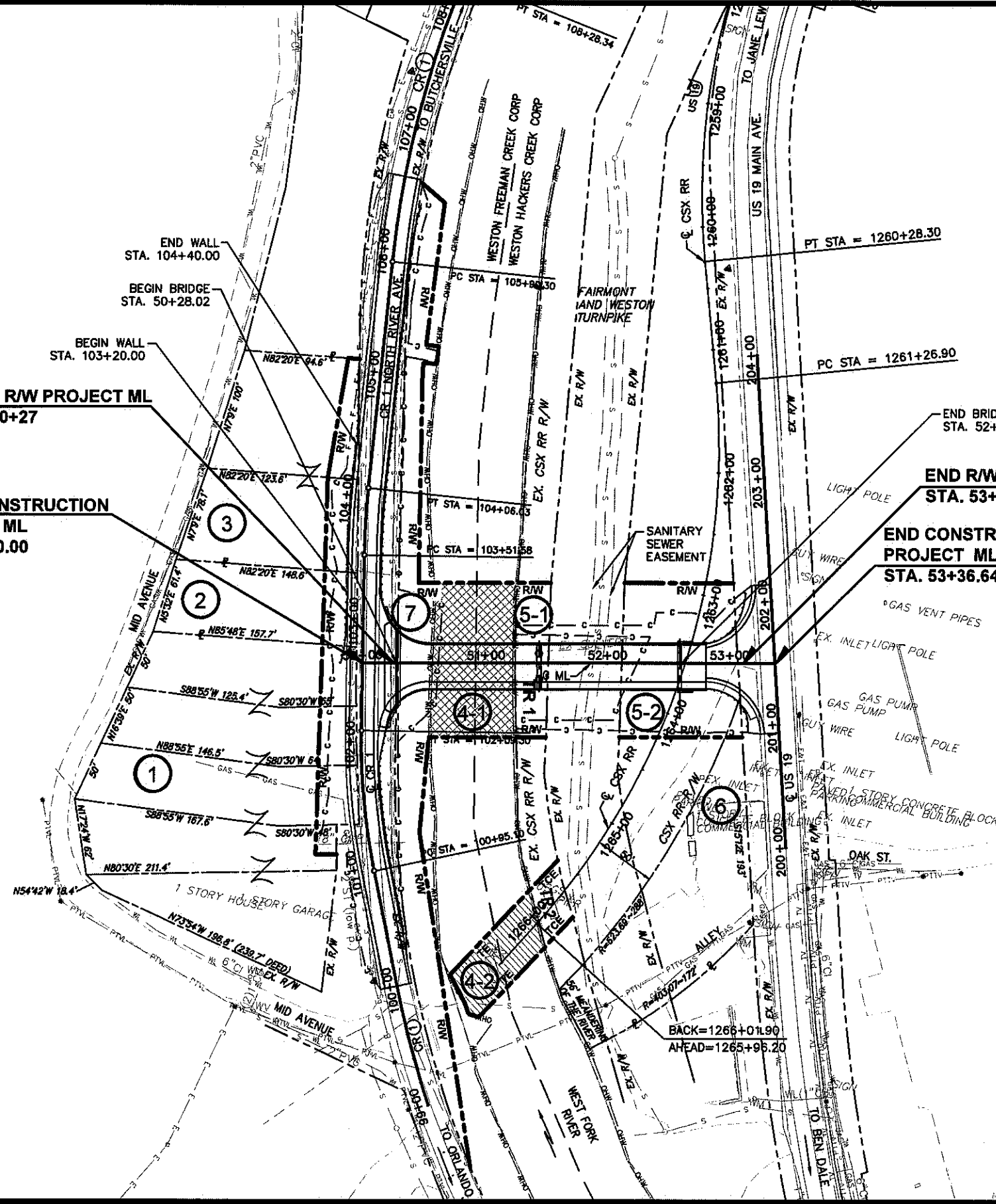

LEGEND
 WEST FORK RIVER
 [Cross-hatched pattern] PAR. 4-1, P.E. 8,668 SF
 [Diagonal hatched pattern] PAR. 4-2, T.E. 3,619 SF
 STATE OF WEST VIRGINIA, DEPARTMENT OF COMMERCE, DIVISION OF NATURAL RESOURCES

THE LOCATIONS OF EXISTING RIGHT-OF-WAY LINES FOR US 19 WERE DETERMINED FROM THE "PLAN AND PROFILE FOR CONSTRUCTION" PLAN SET FOR PROJECT NO. F.A. 220-B(1) FOR US 19, BY THE STATE ROAD COMMISSION OF WEST VIRGINIA DATED 1937.

THE LOCATIONS OF EXISTING RIGHT-OF-WAY LINES FOR CR-1 AND THE RAIL ROAD RIGHT-OF-WAY WERE DETERMINED FROM THE "RIGHT-OF-WAY AND TRACK MAP BY THE BALTIMORE AND OHIO RAILROAD COMPANY MAP I-WV-56.1 (12a) DATED 1952 AND FROM DISTRICT 7 RIGHT-OF-WAY DEPARTMENT REPORTS OF 30' STATUTORY RIGHT-OF-WAY FOR COUNTY ROUTE 1.

FAIRMONT AND WESTON TURNPIKE CHARTERED MARCH 9, 1848.



5 OCTOBER 2021

P.O. Box 483
 Barboursville, WV 25504
 www.jbtengineering.com
 304-733-1335



J.B. TURMAN ENGINEERING, PLLC

REVISION NUMBER	SHEET NUMBER	REVISION	DATE	BY

**FOURTH STREET ARCH BRIDGE
 CONNECTING CR 1 AND US 19
 OVER WEST FORK RIVER**

THE WEST VIRGINIA DEPARTMENT OF TRANSPORTATION
 DIVISION OF HIGHWAYS

PROPERTY MAP

MATCHLINE CR 1 STA. 103+80.00 SHEET 6

PUBLIC ROADS DIV.	STATE DIST. NO.	STATE PROJECT NO.	FEDERAL PROJECT NO.	FISCAL YEAR	COUNTY	SHEET NO.	TOTAL SHEETS
WV	7	S321-N 16/70-0.02 00	STP-1670(002)DTC	2021	LEWS	4	12

THIS PROJECT IS LOCATED ENTIRELY IN THE CITY OF WESTON

END WORK US 19
STA. 202+14.03
(MATCH EXISTING)

CR 1 CURVE #1 DATA		
STATION	COORDINATES	
	NORTHING	EASTING
PC STA. = 100+95.10	745845.833	2120196.906
PI STA. = 101+52.42	745898.410	2120174.075
PT STA. = 102+09.30	745954.639	2120162.946
GEOMETRIC DATA		
$\Delta = 12^{\circ}16'35"$ RIGHT	L = 114.20'	
Dc = 10'44'59"	Ch. = 113.98'	
R = 533.00'	E = 3.07'	
T = 57.32'	M = 3.06'	

CR 1 CURVE #2 DATA		
STATION	COORDINATES	
	NORTHING	EASTING
PC STA. = 103+51.58	746094.217	2120135.319
PI STA. = 103+78.82	746120.940	2120130.030
PT STA. = 104+06.03	746148.033	2120127.184
GEOMETRIC DATA		
$\Delta = 05^{\circ}11'57"$ RIGHT	L = 54.45'	
Dc = 9'32'57"	Ch. = 54.43'	
R = 600.00'	E = 0.62'	
T = 27.24'	M = 0.62'	

END R/W PROJECT ML
STA. 53+10

END CONSTRUCTION
PROJECT ML
STA. 53+24.71

BEGIN WORK US 19
STA. 200+93.54
(MATCH EXISTING)

THE LOCATIONS OF EXISTING RIGHT-OF-WAY LINES FOR US 19 WERE DETERMINED FROM THE "PLAN AND PROFILE FOR CONSTRUCTION" PLAN SET FOR PROJECT NO. F.A. 220-B(1) FOR US 19, BY THE STATE ROAD COMMISSION OF WEST VIRGINIA DATED 1937.

THE LOCATIONS OF EXISTING RIGHT-OF-WAY LINES FOR CR-1 AND THE RAIL ROAD RIGHT-OF-WAY WERE DETERMINED FROM THE "RIGHT-OF-WAY AND TRACK MAP BY THE BALTIMORE AND OHIO RAILROAD COMPANY MAP I-WV-56.1 (12a) DATED 1952 AND FROM DISTRICT 7 RIGHT-OF-WAY DEPARTMENT REPORTS OF 30' STATUTORY RIGHT-OF-WAY FOR COUNTY ROUTE 1.

FAIRMONT AND WESTON TURNPIKE CHARTERED MARCH 9, 1848.

LEGEND
WEST FORK RIVER

PAR. 4-1, P.E. 8,668 SF

PAR. 4-2, T.E. 3,619 SF

SCALE



STATE OF WEST VIRGINIA DEPARTMENT OF COMMERCE DIVISION OF NATURAL RESOURCES

THE WEST VIRGINIA DEPARTMENT OF TRANSPORTATION DIVISION OF HIGHWAYS

ROW PLAN SHEET

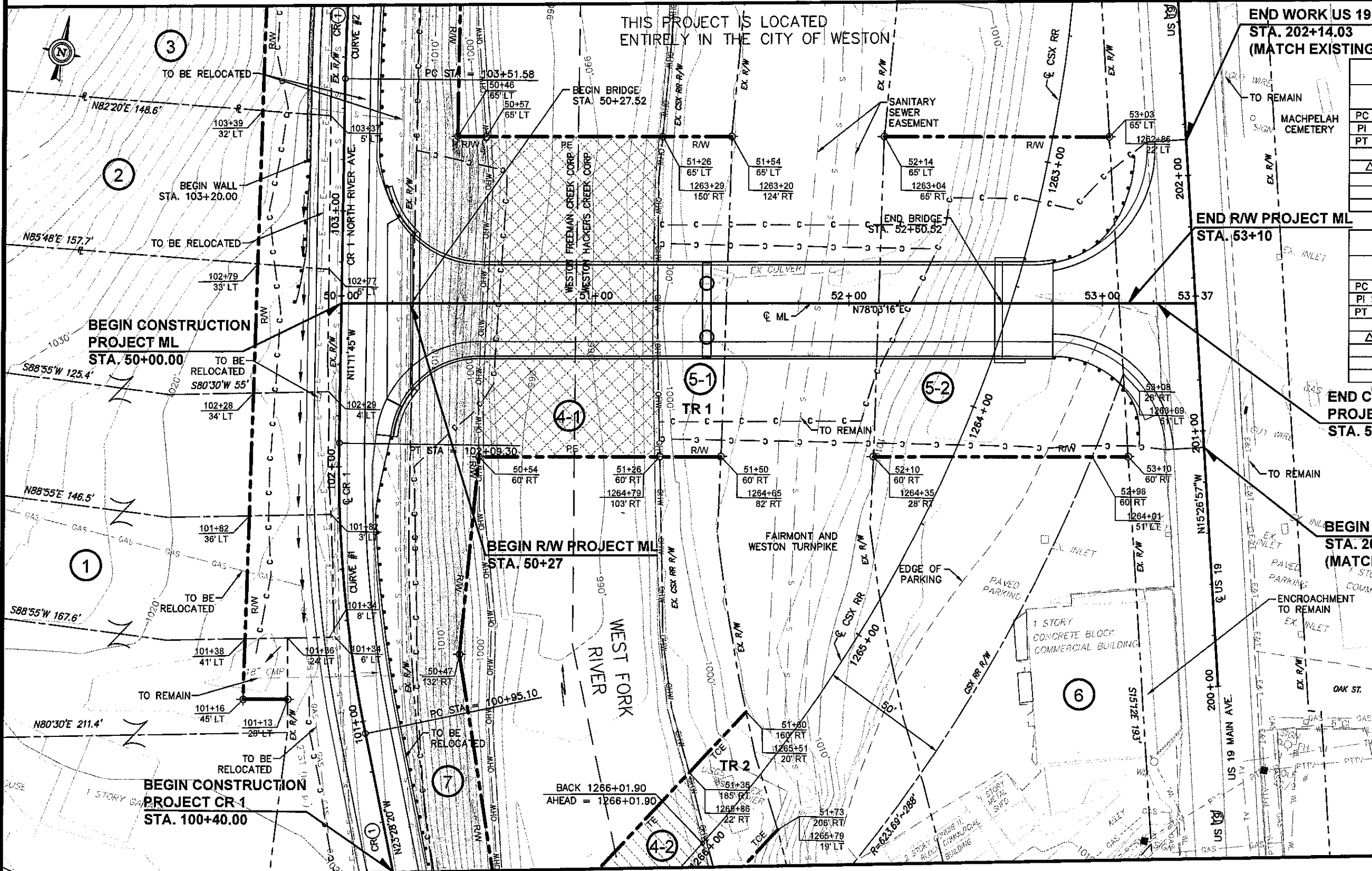

MATCHLINE CR 1 STA. 100+40.00 SHEET 5

P.O. Box 483
Barboursville, WV 25504
www.jbtengineering.com
304-733-1335



J.B. TURMAN ENGINEERING, PLLC

REVISION NUMBER	SHEET NUMBER	REVISION	DATE	BY

FOURTH STREET ARCH BRIDGE
CONNECTING CR 1 AND US 19
OVER WEST FORK RIVER

5 OCTOBER 2021

PUBLIC ROADS DIV.	STATE DIST. NO.	STATE PROJECT NO.	FEDERAL PROJECT NO.	FISCAL YEAR	COUNTY	SHEET NO.	TOTAL SHEETS
WV	7	5321-N 16/70-0.02 00	STP-1670(002)DTC	2021	LEWS	5	12

MATCHLINE CR 1 STA. 100+40.00 SHEET 4

THIS PROJECT IS LOCATED ENTIRELY IN THE CITY OF WESTON

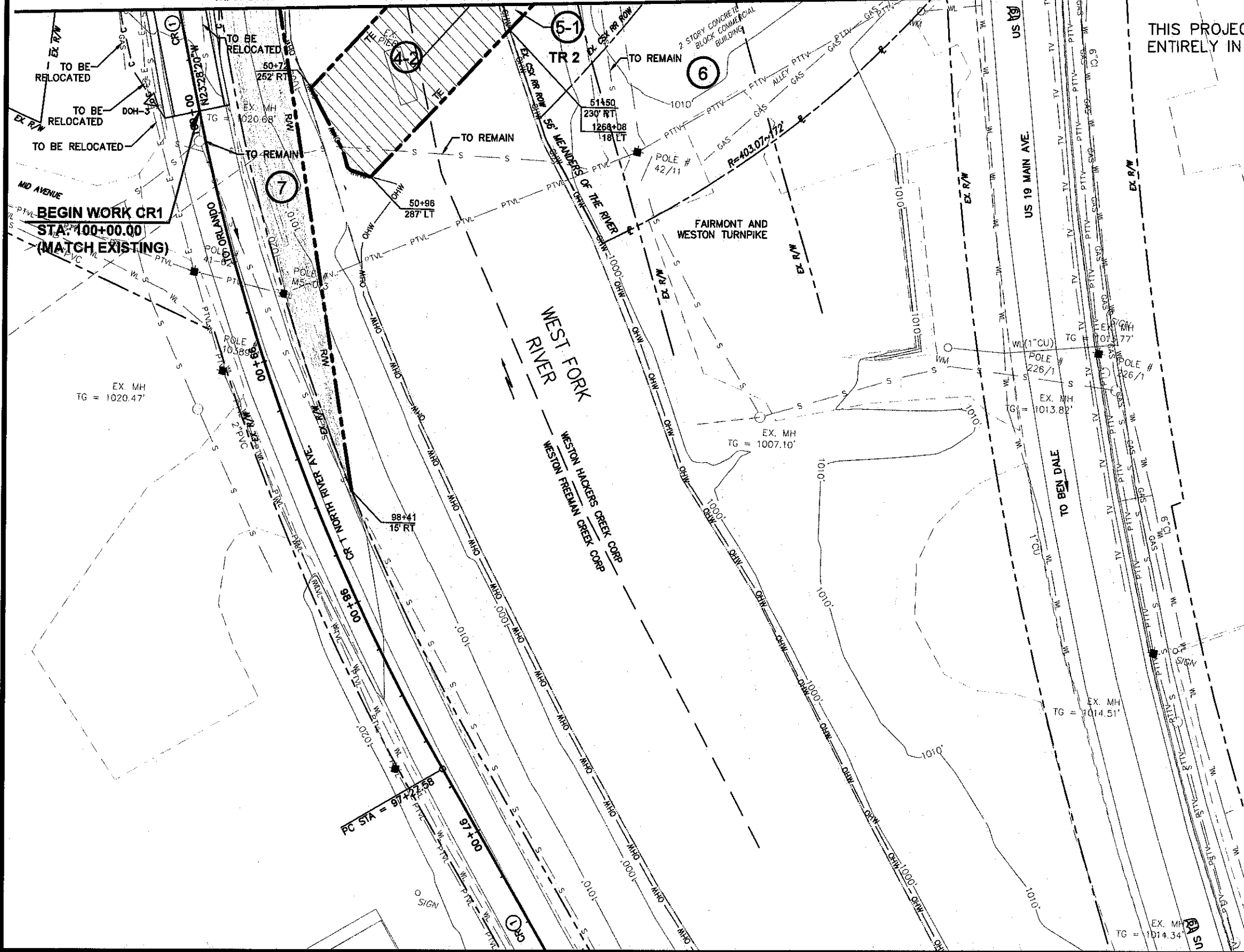

LEGEND
WEST FORK RIVER

PAR. 4-2, T.E. 3,619 SF

STATE OF WEST VIRGINIA DEPARTMENT OF COMMERCE DIVISION OF NATURAL RESOURCES

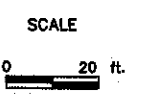

5 OCTOBER 2021

P.O. Box 483
Barboursville, WV 25504
www.jbtengineering.com
304-733-1335



J.B. TURMAN ENGINEERING, PLLC

REVISION NUMBER	SHEET NUMBER	REVISION	DATE	BY

**FOURTH STREET ARCH BRIDGE
CONNECTING CR 1 AND US 19
OVER WEST FORK RIVER**

THE WEST VIRGINIA DEPARTMENT OF TRANSPORTATION
DIVISION OF HIGHWAYS

ROW PLAN SHEET

PUBLIC ROADS DIV.	STATE DIST. NO.	STATE PROJECT NO.	FEDERAL PROJECT NO.	FISCAL YEAR	COUNTY	SHEET NO.	TOTAL SHEETS
WV	7	S321-N 16/70-0.02 00	STP-1670(002)DTC	2021	LEWIS	6	12

THIS PROJECT IS LOCATED ENTIRELY IN THE CITY OF WESTON



CR 1 CURVE #2 DATA		
STATION	COORDINATES	
	NORTHING	EASTING
PC STA. = 103+51.58	746094.217	2120135.319
PI STA. = 103+78.82	746120.940	2120130.030
PT STA. = 104+06.03	746148.033	2120127.184
GEOMETRIC DATA		
$\Delta = 05^{\circ}11'57''$ RIGHT	L = 54.45'	
Dc = 9'32.57"	Ch. = 54.43'	
R = 600.00'	E = 0.62'	
T = 27.24'	M = 0.62'	

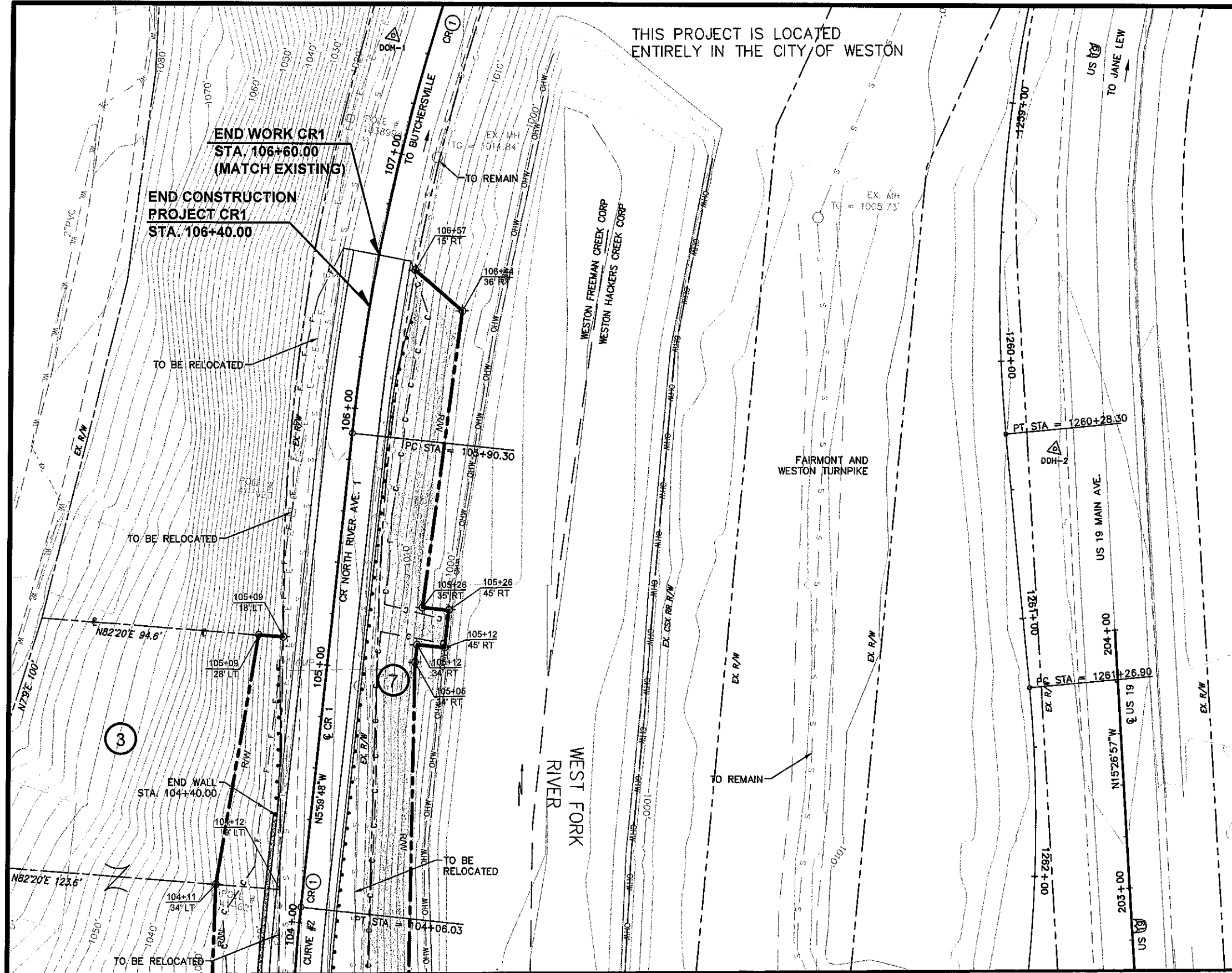

3

MATCHLINE CR 1 STA. 103+80.00 SHEET 4

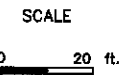

5 OCTOBER 2021

P.O. Box 483
Barboursville, WV 25504
www.jbtengineering.com
304-733-1335



J.B. TURMAN ENGINEERING, PLLC

REVISION NUMBER	SHEET NUMBER	REVISION	DATE	BY

**FOURTH STREET ARCH BRIDGE
CONNECTING CR 1 AND US 19
OVER WEST FORK RIVER**

THE WEST VIRGINIA DEPARTMENT OF TRANSPORTATION
DIVISION OF HIGHWAYS

ROW PLAN SHEET

PUBLIC ROADS DIV.	STATE DIST. NO.	STATE PROJECT NO.	FEDERAL PROJECT NO.	FISCAL YEAR	COUNTY	SHEET NO.	TOTAL SHEETS
WV	7	S321-N 16/70-0.02 00	STP-1670(002)DTC	2021	LEWIS	7	12

CR 1 CURVE #1 DATA		
STATION	COORDINATES	
	NORTHING	EASTING
PC STA. = 100+95.10	745845.833	2120196.906
PI STA. = 101+52.42	745898.410	2120174.075
PT STA. = 102+09.30	745954.639	2120162.946
GEOMETRIC DATA		
$\Delta = 12^{\circ}16'35"$ RIGHT	L = 114.20'	
Dc = 10'44'59"	Ch. = 113.98'	
R = 533.00'	E = 3.07'	
T = 57.32'	M = 3.06'	

CR 1 CURVE #2 DATA		
STATION	COORDINATES	
	NORTHING	EASTING
PC STA. = 103+51.58	746094.217	2120135.319
PI STA. = 103+78.82	746120.940	2120130.030
PT STA. = 104+06.03	746148.033	2120127.184
GEOMETRIC DATA		
$\Delta = 05^{\circ}11'57"$ RIGHT	L = 54.45'	
Dc = 9'32'57"	Ch. = 54.43'	
R = 600.00'	E = 0.62'	
T = 27.24'	M = 0.62'	

DOH-1
 NORTHING: 746484.7980
 EASTING: 2120090.9130
 ELEVATION: 1014.18

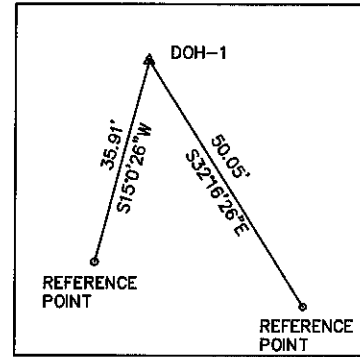

SEE PLAN SHEET 6 FOR LOCATION

DOH-3
 NORTHING: 745758.5280
 EASTING: 2120215.9120
 ELEVATION: 1020.44

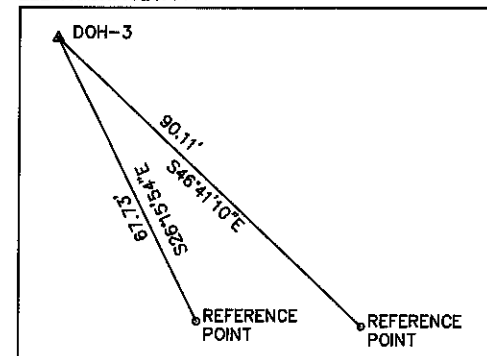

SEE PLAN SHEET 4 FOR LOCATION

DOH-2
 NORTHING: 746328.5880
 EASTING: 2120377.358
 ELEVATION: 1017.79

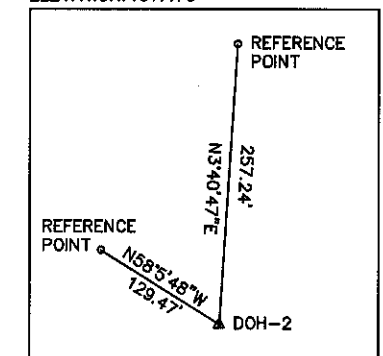

SEE PLAN SHEET 6 FOR LOCATION

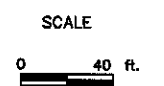
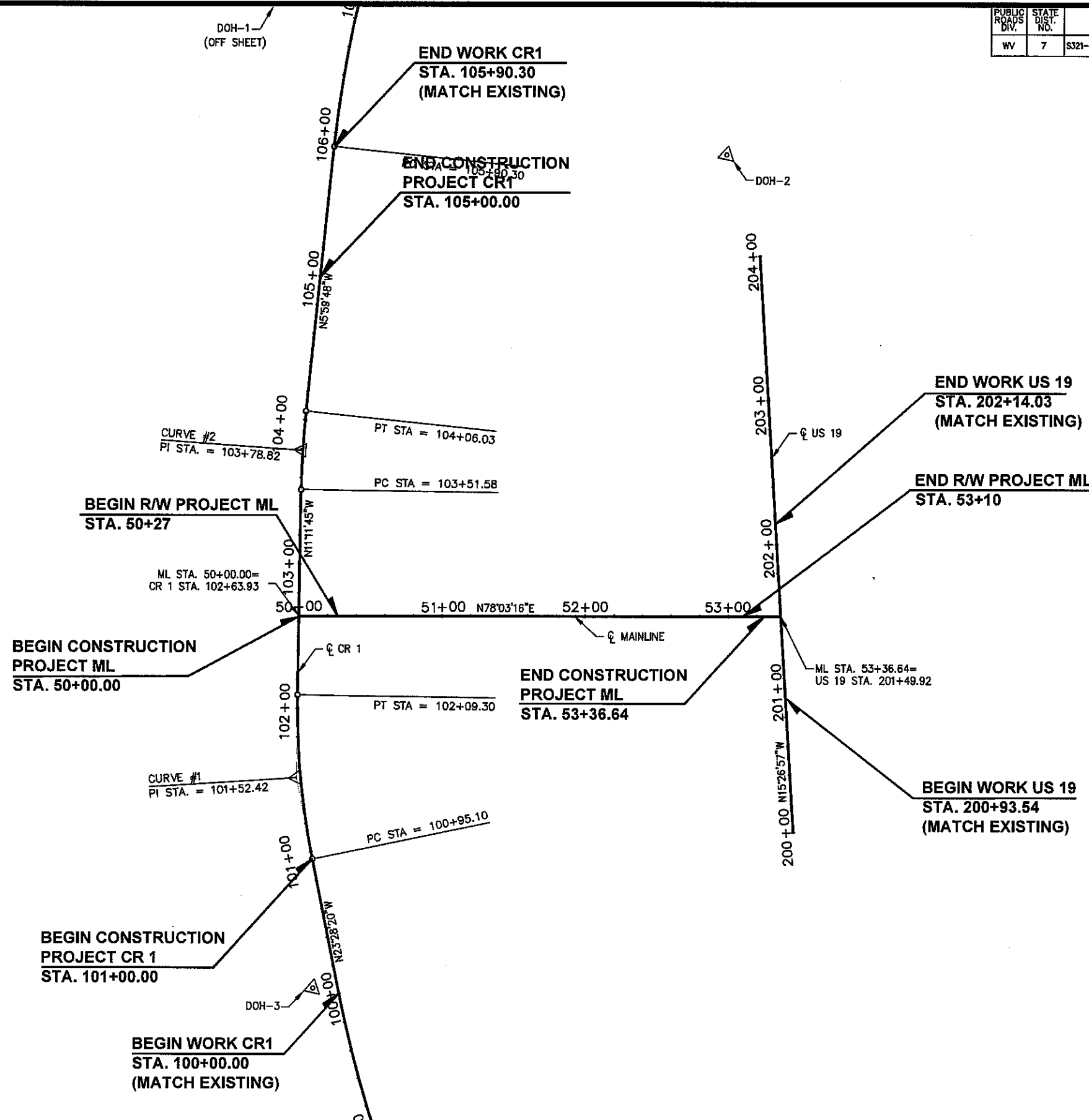

01 MARCH 2021

P.O. Box 483
 Barboursville, WV 25504
 www.jbtengineering.com
 304-733-1335



J.B. TURMAN ENGINEERING, PLLC

REVISION NUMBER	SHEET NUMBER	REVISION	DATE	BY

**FOURTH STREET ARCH BRIDGE
 CONNECTING CR 1 AND US 19
 OVER WEST FORK RIVER**

THE WEST VIRGINIA DEPARTMENT OF TRANSPORTATION
 DIVISION OF HIGHWAYS

GEOMETRIC LAYOUT



REVISION NUMBER	DATE	BY

**FOURTH STREET ARCH BRIDGE
CONNECTING CR 1 AND US 19
OVER WEST FORK RIVER**

TYPICAL SECTIONS

THE WEST VIRGINIA DEPARTMENT OF TRANSPORTATION
DIVISION OF HIGHWAYS

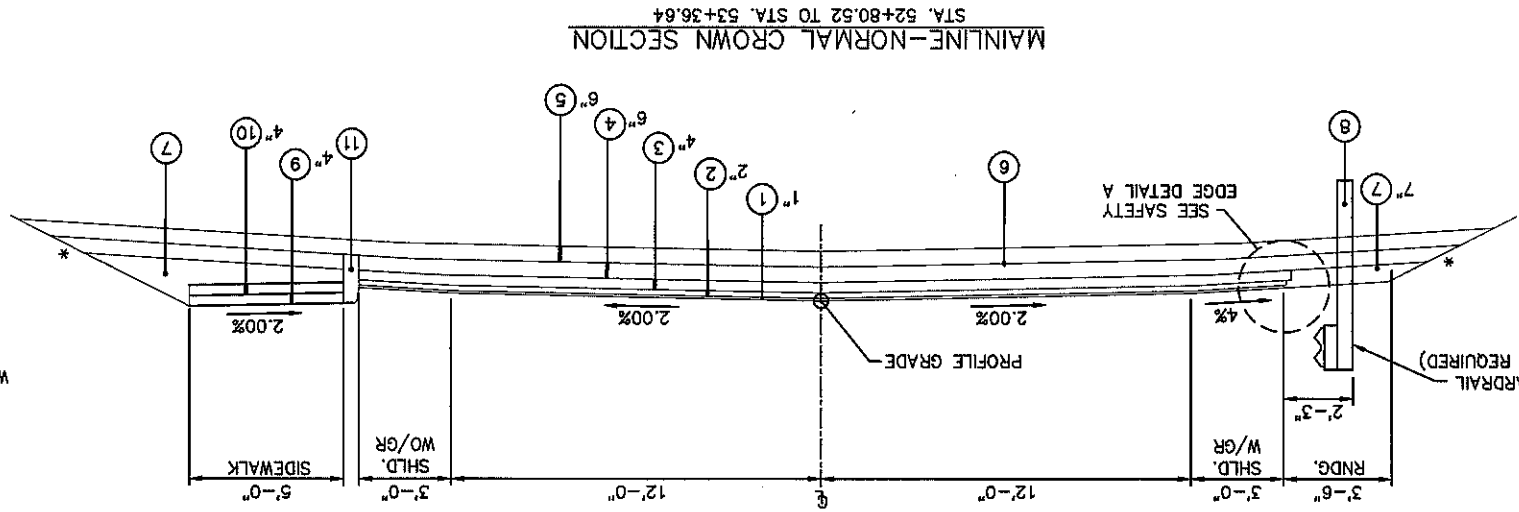
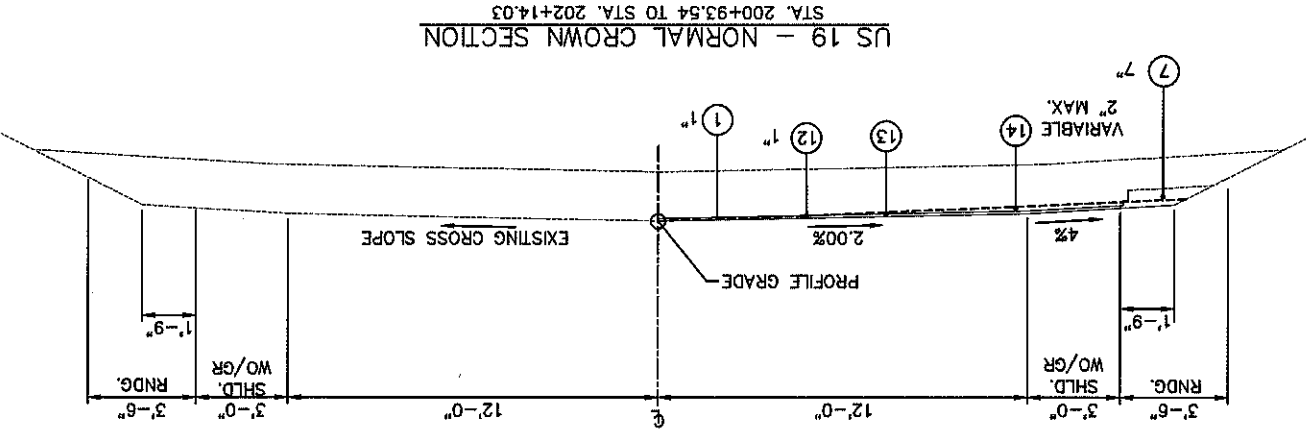
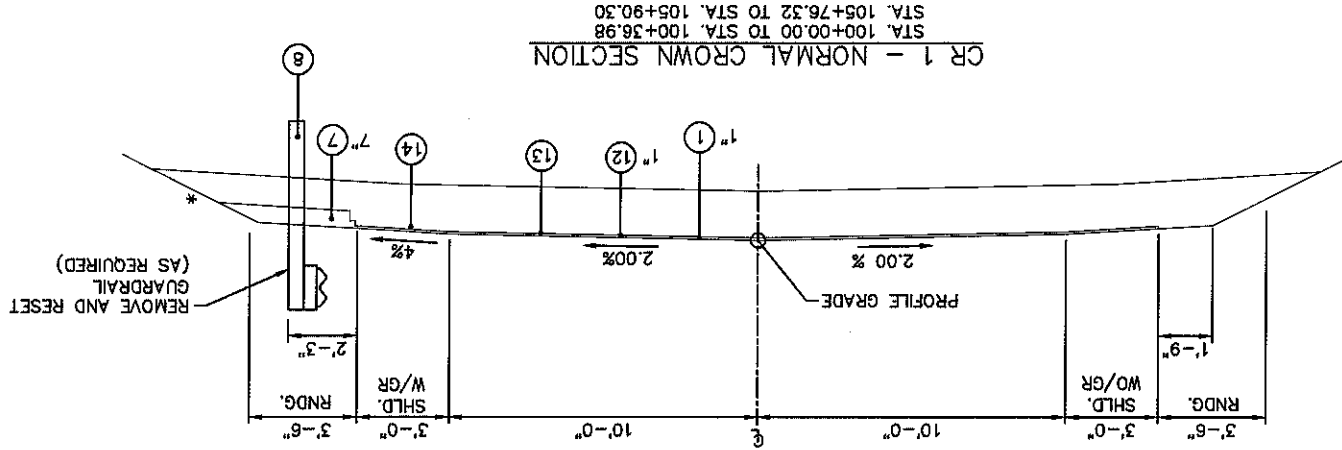

NOTE: THE PAVEMENT USED FOR THIS PROJECT SHALL BE MARSHALL HEAVY MIX DESIGN. THE TERM HEAVY REFERS TO EQUIVALENT SINGLE AXLE LOADS (ESAL'S) AND DOES NOT REFLECT THE QUALITY OF THE ASPHALT. THE DESIGN ESAL VALUE FOR THIS PROJECT IS XX.

* SLOPES VARY -- SEE CROSS SECTIONS

ITEM	DESCRIPTION	UNITS
①	MARSHALL ASPHALT WEARING COURSE, STONE OR GRAVEL (OR SLAG), TYPE I	TN
②	MARSHALL ASPHALT BASE COURSE, STONE OR GRAVEL (OR SLAG), TYPE II	TN
③	MARSHALL ASPHALT BASE COURSE, STONE OR GRAVEL (OR SLAG), TYPE I	TN
④	AGGREGATE BASE COURSE, CLASS 1	CY
⑤	SUBGRADE	CY
⑥	FABRIC FOR SEPARATION	SY
⑦	AGGREGATE BASE COURSE, CLASS 10	TN
⑧	TYPE 1 GUARDRAIL, CLASS I, 31 INCH HEIGHT	LF
⑨	CONCRETE SIDEWALK	SY
⑩	BED COURSE MATERIAL	CY
⑪	PLAIN CONCRETE CURBING, TYPE II	LF
⑫	STANDARD MILLING	SY
⑬	ASPHALT MATERIAL	GA
⑭	PATCHING AND LEVELING AGGREGATE, STONE OR GRAVEL, TYPE II	TN

LEGEND

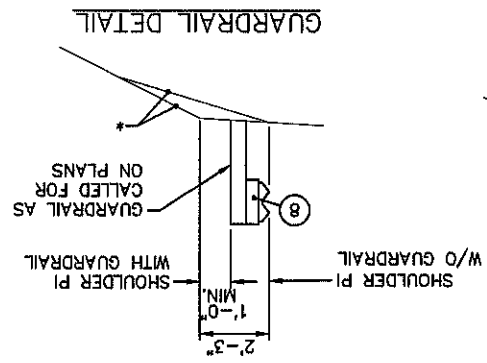
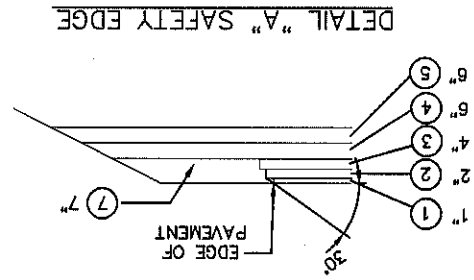

12	8	LEMS	2021	STP-1670(002)DTC	S321-N 16/70-0.02 00	7	WV
TOTAL SHEETS	SHEET NO.	COUNTY	FISCAL YEAR	PROJECT NO.	STATE PROJECT NO.	DIST. NO.	PUBLIC ROADS



REVISION NUMBER	DATE	REVISION

**FOURTH STREET ARCH BRIDGE
CONNECTING CR 1 AND US 19
OVER WEST FORK RIVER**

TYPICAL SECTIONS

THE WEST VIRGINIA DEPARTMENT OF TRANSPORTATION
DIVISION OF HIGHWAYS

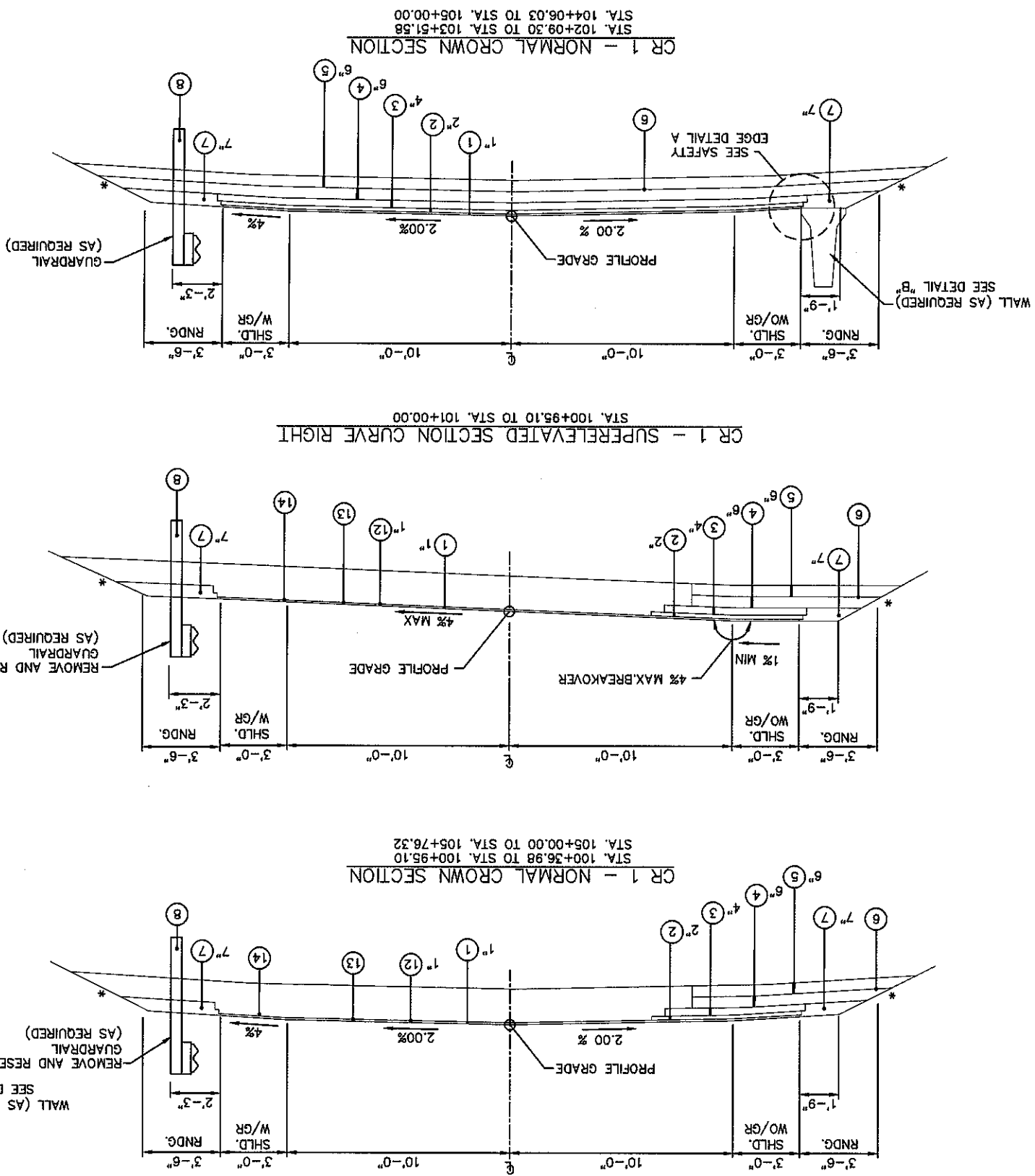

NOTE:
THE PAVEMENT USED FOR THIS PROJECT SHALL BE MARSHALL HEAVY MIX DESIGN. THE TERM HEAVY REFERS TO EQUIVALENT SINGLE AXLE LOADS (ESAL'S) AND DOES NOT REFLECT THE QUALITY OF THE ASPHALT. THE DESIGN ESAL VALUE FOR THIS PROJECT IS XX.
* SLOPES VARY - SEE CROSS SECTIONS

ITEM	DESCRIPTION	UNITS
①	MARSHALL ASPHALT WEARING COURSE, STONE OR GRAVEL, TYPE I, TN	TN
②	MARSHALL ASPHALT BASE COURSE, STONE OR GRAVEL, TYPE II, TN	TN
③	MARSHALL ASPHALT BASE COURSE, STONE OR GRAVEL, TYPE I, TN	TN
④	AGGREGATE BASE COURSE, CLASS 1	CY
⑤	SUBGRADE	CY
⑥	FABRIC FOR SEPARATION	207034-000
⑦	AGGREGATE BASE COURSE, CLASS 10 (OR-002)	307005-001
⑧	TYPE I GUARDRAIL, CLASS I, 31 INCH HEIGHT	607001-001
⑨	CONCRETE SIDEWALK	609001-001
⑩	BED COURSE MATERIAL	609002-001
⑪	PLAIN CONCRETE CURBING, TYPE II	610001-001
⑫	STANDARD MILLING	415005-001
⑬	ASPHALT MATERIAL	408002-001
⑭	PATCHING AND LEVELING AGGREGATE, STONE OR GRAVEL, TYPE II	405002-001

LEGEND

DETAIL "B" WALL

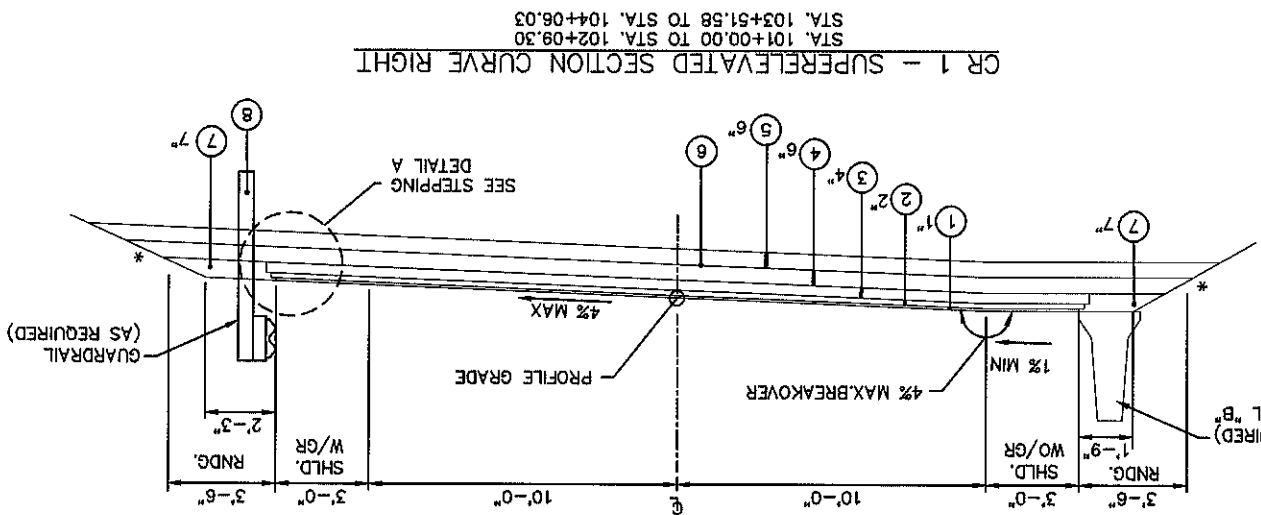
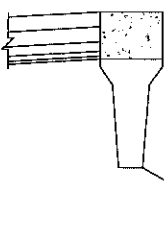

WV	7	SS21-N 16/70-02 00	STP-1670(002)DTC	2021	LEMS	9	12
PUBLIC STATE	ROADS DIST.	PROJECT NO.	FEDERAL PROJECT NO.	FISCAL YEAR	COUNTY	SHEET NO.	TOTAL SHEETS

P.O. Box 483
 Barboursville, WV 25504
 www.jbtengineering.com
 304-733-1335

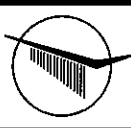

J.B. TURMAN ENGINEERING, PLLC

REVISION NUMBER	SHEET NUMBER	REVISION	DATE	BY

**FOURTH STREET ARCH BRIDGE
 CONNECTING CR 1 AND US 19
 OVER WEST FORK RIVER**

THE WEST VIRGINIA DEPARTMENT OF TRANSPORTATION
 DIVISION OF HIGHWAYS
PROFILE SHEET

PROFILE - MAINLINE

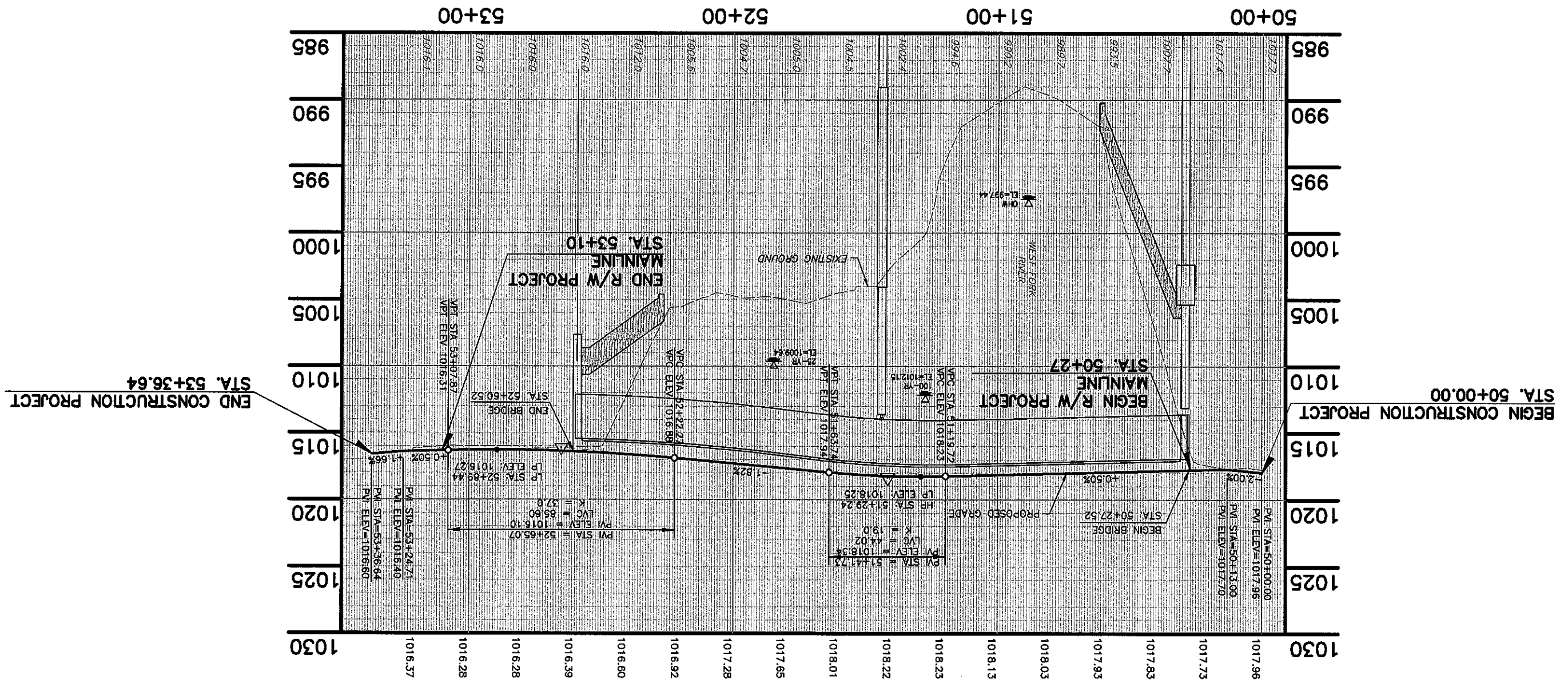
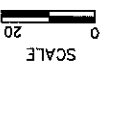

STATE	7								
DIST.									
PROJECT NO.									
FEDERAL PROJECT NO.									
FISCAL YEAR	2021								
COUNTY	LEMS								
SHEET NO.	10								
TOTAL SHEETS	12								



P.O. Box 483
 Barboursville, WV 25504
 www.jbtengineering.com
 304-733-1335



J.B. TURMAN ENGINEERING, PLLC

REVISION	DATE	BY

FOURTH STREET ARCH BRIDGE
 CONNECTING CR 1 AND US 19
 OVER WEST FORK RIVER

THE WEST VIRGINIA DEPARTMENT OF TRANSPORTATION
 DIVISION OF HIGHWAYS
PROFILE SHEET

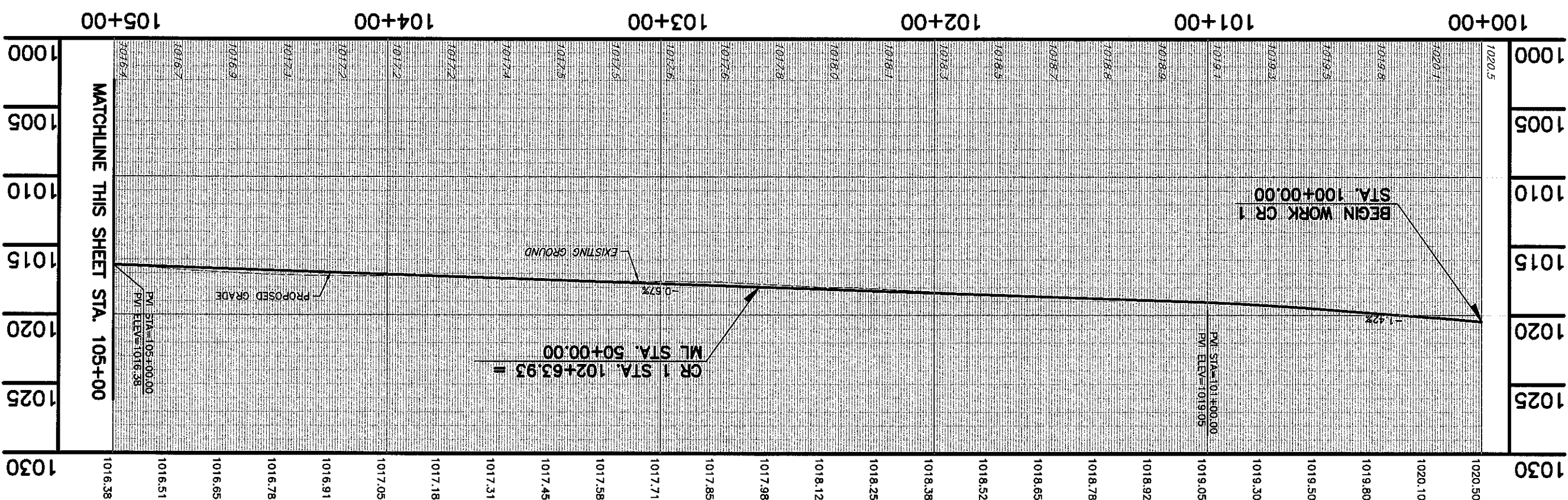
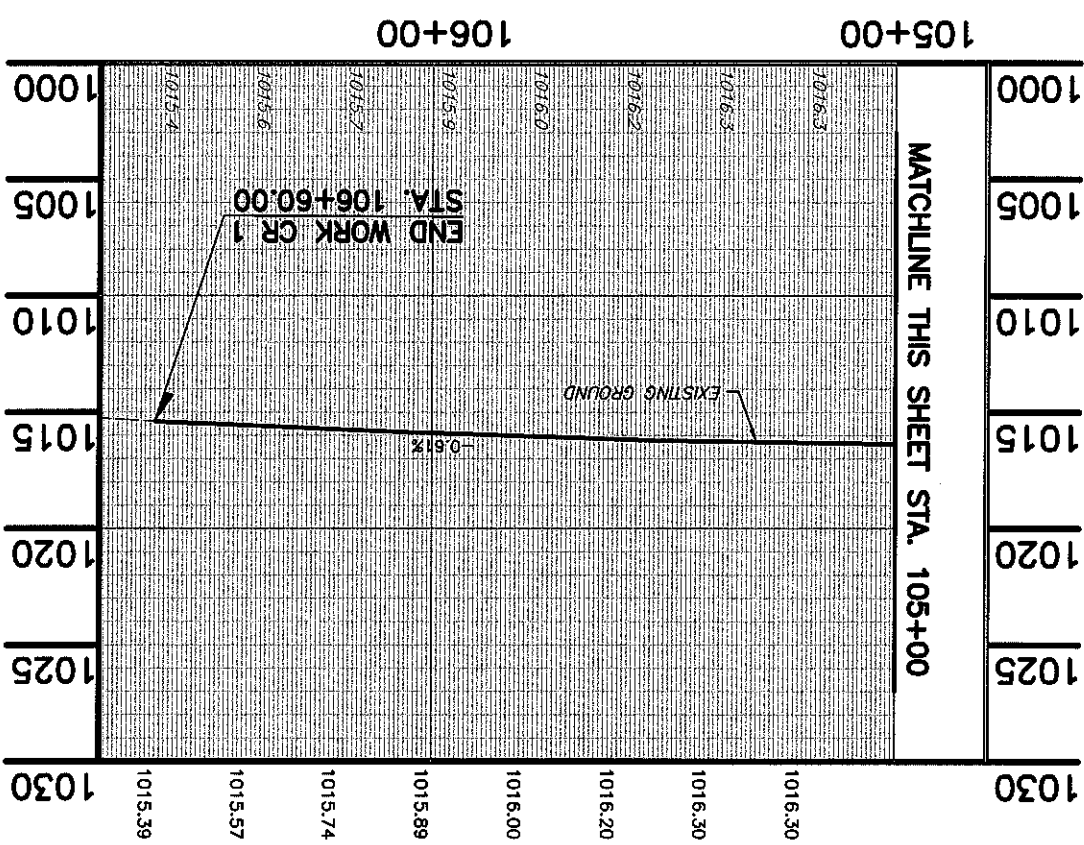

WV	7	S221-N 16/70-0.02 00	STP-1670(002)DTC	2021	LEMS	11	12
ROADS DIV.	STATE DIST.	PROJECT NO.	FEDERAL PROJECT NO.	FISCAL YEAR	COUNTY	SHEET NO.	TOTAL SHEETS

P.O. Box 483
Barboursville, WV 25504
www.jbtengineering.com
304-733-1335



J.B. TURMAN ENGINEERING, PLLC

REVISION NUMBER	SHEET NUMBER	REVISION	DATE	BY

FOURTH STREET ARCH BRIDGE CONNECTING CR 1 AND US 19 OVER WEST FORK RIVER

PROFILE SHEET

THE WEST VIRGINIA DEPARTMENT OF TRANSPORTATION
DIVISION OF HIGHWAYS

PROFILE - US 19

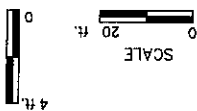
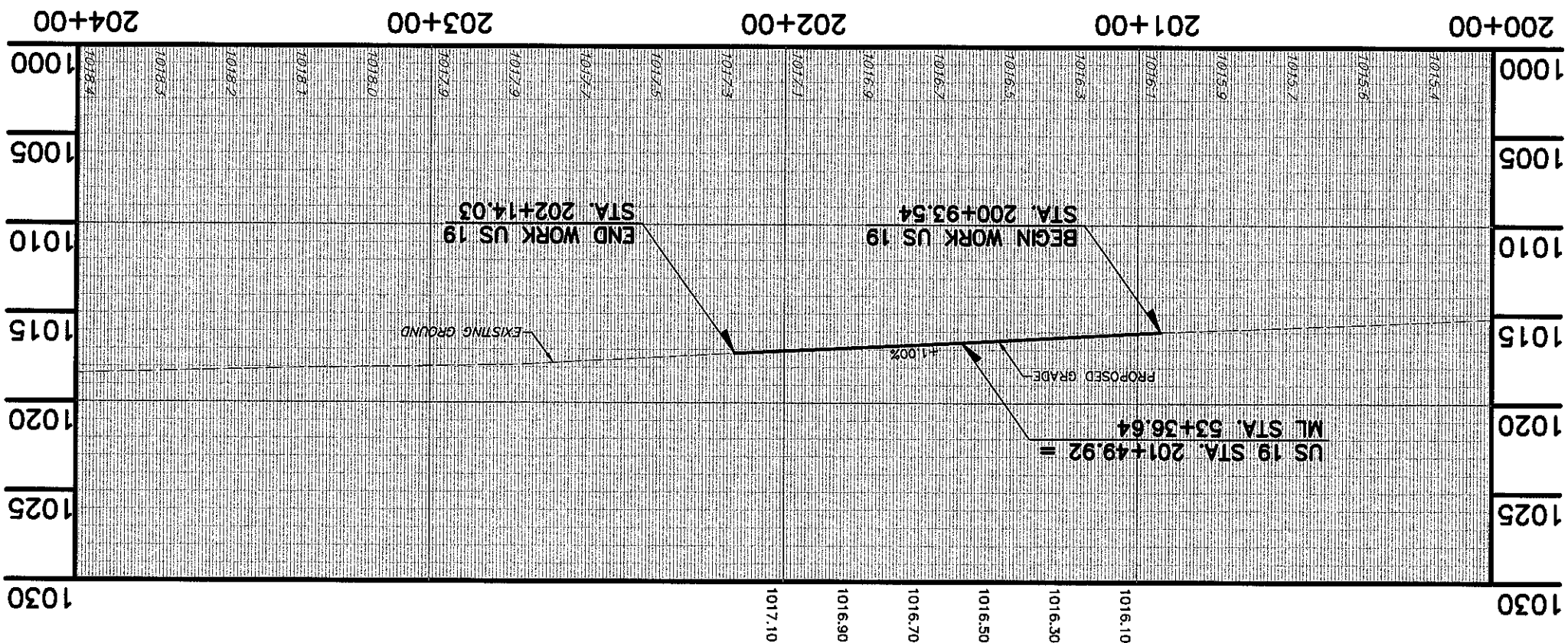

PUBLIC STATE ROADS DIV. NO.	STATE PROJECT NO.	FEDERAL PROJECT NO.	FISCAL YEAR	COUNTY	SHEET NO.	TOTAL SHEETS
WV	7	5321-N 16/70-002 00	2021	LEMS	12	12
		STP-1670(002)DTC				

12. Reports of City Council